

# ENTROPY AND THE SECOND LAW OF THERMODYNAMICS

# W

*e can imagine many processes that never happen, even though they do not violate the law of conservation of energy. For instance, hot coffee resting in a mug might give up some internal thermal energy and spontaneously begin to rotate. A glass of cool water might spontaneously change into an ice cube in a glass of warmer water. Even though such things never happen, we commonly see them happening in the reverse direction. The second law of thermodynamics, the subject of this chapter, deals with the directions in which processes occur. It is often said that the second law gives a preferred direction to the “arrow of time,” telling us that systems naturally evolve with time in one direction but not in the other.*

*We have seen that the zeroth law of thermodynamics leads to the concept of temperature. Similarly, the first law of thermodynamics leads to the concept of internal energy. The second law establishes still another concept; entropy, a quantity in terms of which the second law of thermodynamics is expressed. We will examine entropy from both a macroscopic and a microscopic point of view.*

## 24-1 ONE-WAY PROCESSES

There is a property of things that happen naturally in the world around us that is strange beyond belief. Yet we are so used to it that we hardly ever think about it. It is this:

*All naturally occurring processes proceed in one direction only. They never, of their own accord, proceed in the opposite direction.*

Consider the following examples:

*Example 1:* If you drop a stone, it falls to the ground. A stone resting on the ground never, of its own accord, leaps up into the air.

*Example 2:* A cup of hot coffee left on your desk gradually cools down. It never gets hotter all by itself.

*Example 3:* If you put a drop of ink in a glass of water, the molecules of ink eventually spread uniformly throughout the volume of the water. They never, of their own accord, regroup into a drop-shaped clump.

If you saw any of these processes happen in reverse, you would probably suspect that you had been tricked.

Such spontaneous one-way processes are *irreversible*, which means that once they have started they keep on going. More precisely, you cannot make them go backward by making any small change in their environment. Essentially, all naturally occurring processes are irreversible.

Although the “wrong-way” events we have described above do not occur, none of them would violate the law of conservation of energy. Consider these examples again:

*Example 1:* The ground could spontaneously cool a little, giving up some of its internal thermal energy to the resting stone as kinetic energy, allowing it to leap up. But it does not happen.

*Example 2:* Here we are dealing only with the direction of energy transfer, not with changes in its amount. Energy might flow from the surrounding air into the coffee, instead of the other way around. But it does not.

*Example 3:* Here no energy transfers are involved. All that is needed is for the ink molecules, each of which is free to move throughout the water, all to return simultaneously to somewhere near their original locations. That will never happen.

It is not the *energy* of the system that controls the direction of irreversible processes; it is another property that we introduce in this chapter—the *entropy* (symbol  $S$ ) of the system. Although we have not discussed entropy up to this point, it is just as much a property of the state of a system as are temperature, pressure, volume, and internal energy. We shall define entropy in the following section but, to see where we are going, let us at once state its central property, which we can call the *entropy principle*:

*If an irreversible process occurs in a closed system, the entropy of that system always increases; it never decreases.*

Entropy is different from energy in that it does *not* obey a conservation law. No matter what changes occur within a closed system, the energy of that system remains constant. Its entropy, however, always increases for irreversible processes.

In this chapter we are concerned with *changes* in entropy—that is, with  $\Delta S$  rather than  $S$ . If a process occurs irreversibly in a closed system, the entropy principle tells us that  $\Delta S > 0$ . The “backward” processes that we have described—if they occurred—would have  $\Delta S < 0$  and would violate the entropy principle.

There are two equivalent ways to define the change in the entropy of a system: (1) A macroscopic approach, involving heat transfer and the temperature at which the transfer occurs, and (2) a microscopic approach, involving counting the ways in which the atoms or molecules that make up the system can be arranged. We use the first approach in Section 24-2 and the second in Section 24-9.

## 24-2 DEFINING ENTROPY CHANGE

In this section we define the entropy change  $\Delta S$  that occurs when a closed system changes from a well-defined initial state to an equally well-defined final state by a process that we can describe as *reversible*. In a reversible process, we make a small change in a system and its environment; by reversing that change, the system and its environment will return to their original conditions. For example, when we place a hot block of metal and a cool block of metal into contact, heat is transferred from the hotter block to the cooler one. That is an irreversible process; we cannot reverse any step in the procedure that would cause the heat flow to reverse direction and restore the blocks to their original temperatures. On the other hand, consider a piece of metal on a hot plate at a temper-

ature  $T$ . If we increase the temperature of the hot plate by a small step  $dT$ , a small amount of heat  $dQ$  is transferred from the hot plate to the block. If we then *decrease* the temperature of the hot plate by  $dT$ , an equal amount of heat  $dQ$  is transferred from the block to the hot plate. The block and the hot plate are restored to their original conditions; the heat transferred in this way is done by a reversible process.

For another example, consider the gas in the cylinder shown in Fig. 21-13. If we remove a small amount of lead shot from the container on the piston, a small quantity of heat  $dQ$  will be transferred to the gas from the thermal reservoir; if we replace that amount of lead shot, the same quantity of heat  $dQ$  flows back to the reservoir, and the system and its environment are restored to their original conditions in this reversible process.

In a truly reversible process, there would be no losses of energy due to turbulence, friction, or other dissipative effects. Clearly the reversible process is an abstraction, because all natural processes will result in these types of energy losses and hence be irreversible. For example, if there is friction in the piston of Fig. 21-13, the system will not return to its original configuration when we return the lead shot to the container. However, by improving the apparatus and making other experimental refinements, we can approach arbitrarily close to reversibility. More importantly, the strictly reversible process is a simple and useful abstraction that helps us to analyze and understand more complex processes, just as the ideal gas concept is an abstraction that helps us to understand the behavior of real gases.

We begin our discussion of entropy by simply stating the definition of entropy change for a reversible process and then examining its consequences. The definition is

$$\Delta S = \int_i^f \frac{dQ}{T} \quad (\text{reversible}). \quad (24-1)$$

Here  $dQ$  is the increment of heat energy that is transferred into or out of the (closed) system at (Kelvin) temperature  $T$ , and the integral is evaluated from the initial state  $i$  of the system to its final state  $f$ . Both the heat transferred and the temperature at which the transfer takes place are equally important in defining the entropy change.

If the process is isothermal, so that the heat transfer takes place at a constant temperature  $T$ , then Eq. 24-1 reduces to

$$\Delta S = \frac{Q}{T} \quad (\text{reversible, isothermal}). \quad (24-2)$$

Because the (Kelvin) temperature  $T$  is always positive, it follows from Eqs. 24-1 and 24-2 that the entropy change has the same algebraic sign as the heat  $Q$ . That is, if heat energy is *added* (reversibly) to a closed system ( $Q > 0$ ), the entropy of that system *increases* ( $\Delta S > 0$ ) and conversely. The unit of entropy that follows from its defining equation is the joule/kelvin.

## Entropy as a State Property

If entropy, like pressure, internal energy, and temperature, were not a true property of a given equilibrium state of a system, we would not find it a useful quantity. Let us now prove specifically that entropy is such a *state property* for the important case of an ideal gas.

We write the first law of thermodynamics in differential form as

$$dQ + dW = dE_{\text{int}}.$$

We then replace  $dW$  with  $-p dV$ , and we use Eq. 23-31 to replace  $dE_{\text{int}}$  with  $nC_V dT$ . Solving for  $dQ$  then leads to

$$dQ = p dV + nC_V dT.$$

Using the ideal gas law, we replace  $p$  in this equation with  $nRT/V$  and we then divide each term in the resulting equation by  $T$ . This gives us

$$\frac{dQ}{T} = nR \frac{dV}{V} + nC_V \frac{dT}{T}.$$

Now let us integrate each term of this equation between an arbitrary initial state  $i$  and an arbitrary final state  $f$ . The quantity on the left is then the entropy change defined by Eq. 24-1, so we get

$$\Delta S = nR \ln \frac{V_f}{V_i} + nC_V \ln \frac{T_f}{T_i}.$$

We did not specify a path in carrying out the integration, so the above result must hold for all (reversible) paths. Thus the change in entropy between the initial and final states of an ideal gas depends only on properties of the initial state ( $T_i$  and  $V_i$ ) and of the final state ( $T_f$  and  $V_f$ ). It is totally independent of the process by which the ideal gas moves from its initial to its final state. Thus entropy is indeed a state property, characteristic of the particular state of a system and *not* dependent on how the system arrived at that state.

**SAMPLE PROBLEM 24-1.** An insulating vessel containing 1.8 kg of water is placed on a hot plate, both the water and hot plate being initially at 20°C. The temperature of the hot plate is raised very slowly to 100°C, at which point the water begins to boil. What is the entropy change of the water during this process?

**Solution** The water and the hot plate are essentially in thermal equilibrium at all times so that the process is reversible. That is, by lowering the temperature of the hot plate slightly at any stage of the process, we could cause the temperature of the water to stop rising and to begin to fall. We choose the water alone as our system and, because the process is reversible, we can use Eq. 24-1 to calculate the entropy change.

The heat energy required to raise the temperature of the water by an amount  $dT$  is

$$dQ = mc dT$$

in which  $m$  is the mass of the water and  $c$  is the specific heat of water. Equation 24-1 then becomes

$$\begin{aligned} \Delta S &= \int_{T_i}^{T_f} \frac{mc dT}{T} \\ &= mc \int_{T_i}^{T_f} \frac{dT}{T} = mc \ln \frac{T_f}{T_i} \\ &= (1.8 \text{ kg})(4190 \text{ J/kg} \cdot \text{K}) \ln \frac{(273 + 100) \text{ K}}{(273 + 20) \text{ K}} \\ &= 1820 \text{ J/K}. \end{aligned}$$

Note that, as part of the definition of  $\Delta S$ , we had to change the initial and final temperatures from the Celsius to the Kelvin scale. Because heat is transferred to the system to increase its temperature, the change in the entropy of the system is positive.

## 24-3 ENTROPY CHANGE FOR IRREVERSIBLE PROCESSES

We can use Eq. 24-1 to calculate the entropy change for a process only if that process is reversible. However, a reversible process—like an ideal gas—is an idealization. All processes that we encounter in the real world involve friction or turbulence, or have some other aspect that makes them essentially irreversible. How, then, do we calculate the entropy change for an irreversible process?

We rely on the fact that entropy is a state property. That is, when a closed system proceeds from an initial state  $i$  to a final state  $f$ , the entropy change depends only on the properties of these two states. It does not depend at all on the process that connects the states or even whether that process is reversible or irreversible. Thus, we can find the entropy change  $\Delta S$  for a system that proceeds from state  $i$  to state  $f$  by an irreversible process using the following procedure:

1. Find a reversible process that connects these same two states. Any of the many such processes will do. It makes sense to choose the simplest.

2. Use Eq. 24-1 to calculate  $\Delta S$  for this chosen *equivalent reversible process*. The result will hold for the original irreversible process as well.

Let us explore this prescription for what must be one of the most familiar of irreversible processes, the falling stone of Example 1 in Section 24-1. Figure 24-1a shows the initial state of the system. For convenience, we allow the stone to fall into a thermally insulated bucket of water. Figure 24-1b shows the final state. The stone now rests in the bucket and the temperature of the water and the resting stone has risen from an initial value  $T_i$  to a final value  $T_f$ .

We take as our system *stone + water*. No heat energy is transferred through the boundary of this system so that  $Q = 0$ . Work, in amount  $m_s gh$ , where  $m_s$  is the mass of the stone, is done on the system by the gravitational force that acts on the stone. Thus  $W = +m_s gh$ . From the first law of thermodynamics, we must then have

$$\Delta E_{\text{int}} = Q + W = 0 + m_s gh = +m_s gh.$$

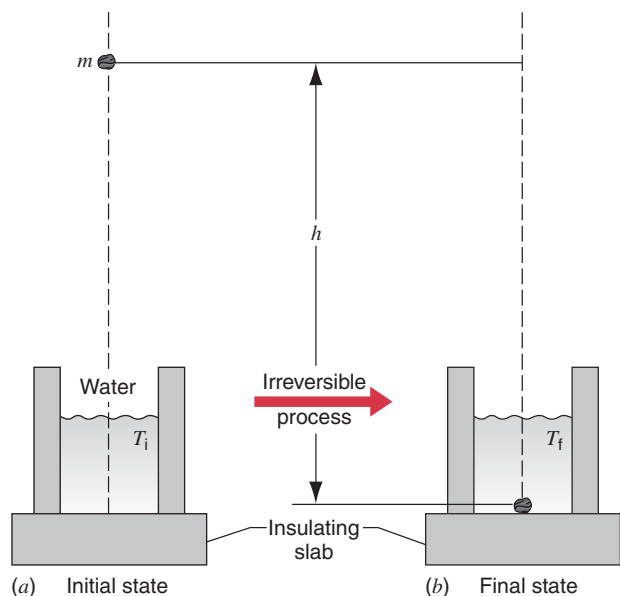

**FIGURE 24-1.** An irreversible process between two equilibrium states. A stone of mass  $m$  is dropped from a height  $h$  into water contained in a thermally insulated bucket. The temperature of the water (and the stone) rises from an initial value  $T_i$  to a higher value  $T_f$ .

This increase in internal energy shows up as a small increase in the temperature of the water–stone system.

Now, following step 1 of our procedure, let us find an equivalent reversible process that connects the two states of Fig. 24-1. In Fig. 24-2a, we place the water bucket, not on an insulating slab, but on a thermal reservoir whose controllable temperature we set to  $T_i$ . We do not allow the stone to fall freely but we attach it to a string and lower it very slowly. After the stone is in the water, we increase the temperature of the reservoir slowly to  $T_f$ , using the temperature control knob. The initial and final states in Fig. 24-2 are exactly the same as those in Fig. 24-1.

The process of Fig. 24-2 is truly reversible. We could change the direction of the process at any stage by making small adjustments in the environment of the system—that is, by raising the stone instead of lowering it and by extracting heat energy instead of adding it.

Now let us examine the energy transfers that occur in the equivalent reversible process of Fig. 24-2. The net force acting on the stone is now zero, the force of gravity being balanced by the upward-directed tension in the string. Thus  $W = 0$ . Because the initial and final states of Fig. 24-2 are the same as those for Fig. 24-1 (and the internal energy is a state property) we must have  $\Delta E_{\text{int}} = +m_s gh$  in each case. From the first law of thermodynamics we then have

$$\begin{aligned} Q &= \Delta E_{\text{int}} - W \\ &= m_s gh - 0 = +m_s gh. \end{aligned} \quad (24-3)$$

Heat in this amount must enter the system from the thermal reservoir if we are to increase the system temperature from

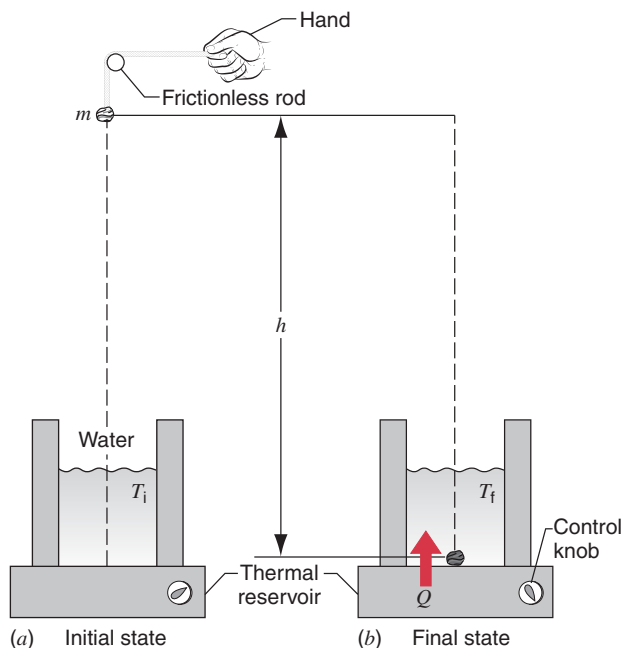

**FIGURE 24-2.** A reversible process connecting the same initial and final states shown in Fig. 24-1. The water bucket now rests on a *thermal reservoir* whose temperature can be adjusted by means of a control knob. First the stone is lowered slowly at the end of a string. Then the temperature of the water (and the stone) is increased slowly from  $T_i$  to  $T_f$  by adjusting the temperature control knob. During this process, heat energy  $Q$  is transferred from the reservoir to the water.

$T_i$  to  $T_f$ . Knowing  $Q$ , we can then calculate the entropy change for the equivalent reversible process, using Eq. 24-1; see Sample Problem 24-2. Because  $Q$  is positive (heat *enters* the system) the entropy change will also be positive. *This same (positive) entropy change also holds for the irreversible process of Fig. 24-1.*

In the following three sample problems, we will examine three irreversible processes that occur in closed systems and will show that, in accord with the entropy principle, the entropy always increases.

**SAMPLE PROBLEM 24-2.** A stone of mass  $m_s = 1.5$  kg falls through a vertical height  $h = 2.5$  m into a bucket containing a mass  $m_w = 4.5$  kg of water, as in Fig. 24-1. The initial temperatures of the water and the stone are 300 K. (a) What is the temperature rise  $\Delta T$  of the system *water + stone*? (b) What is the entropy change  $\Delta S$  of this system? (c) What would be the entropy change for the reverse process—that is, for the system to cool down, transferring its energy to the stone in kinetic form, allowing it to leap 2.5 m into the air? (It will never happen!) The specific heat of water is  $c_w = 4190$  J/kg·K and that of the stone material is  $c_s = 790$  J/kg·K.

**Solution** (a) Figure 24-2 shows an equivalent reversible process that we can use to calculate the entropy change of the falling stone. In terms of the temperature change  $\Delta T$  of both the water

and the stone, the heat transfer  $Q$  in the equivalent reversible process of Fig. 24-2b is

$$Q = m_w c_w \Delta T + m_s c_s \Delta T, \quad (24-4)$$

a positive quantity. We have seen from Eq. 24-3 that  $Q$  is also given by

$$Q = m_s gh = (4.5 \text{ kg})(9.8 \text{ m/s}^2)(2.5 \text{ m}) = +110 \text{ J}.$$

Substituting this value for  $Q$  into Eq. 24-4 and solving for  $\Delta T$  yields

$$\begin{aligned} \Delta T &= \frac{Q}{m_w c_w + m_s c_s} \\ &= \frac{+110 \text{ J}}{(4.5 \text{ kg})(4190 \text{ J/kg} \cdot \text{K}) + (1.5 \text{ kg})(790 \text{ J/kg} \cdot \text{K})} \\ &= +5.5 \times 10^{-3} \text{ K} = +5.5 \text{ mK}. \end{aligned}$$

Because temperature is a state property, this calculated temperature rise holds both for the equivalent reversible process of Fig. 24-2 and for the original irreversible process of Fig. 24-1.

(b) Now let us calculate the entropy change for the equivalent reversible process of Fig. 24-2. The temperature change (5.5 mK) is so small that we can say that heat  $Q$  is transferred from the reservoir to the system at essentially a constant temperature of 300 K. Thus we can calculate  $\Delta S$  from Eq. 24-2. From that equation, then

$$\Delta S = \frac{Q}{T} = \frac{+110 \text{ J}}{300 \text{ K}} = +0.37 \text{ J/K}.$$

Note that heat  $Q$  is transferred *into* the system from the reservoir and is thus positive. Therefore  $\Delta S$  is also positive, signifying an *increase* in entropy.

Although we have calculated  $\Delta S$  for the reversible process of Fig. 24-2 it applies equally well to the irreversible process of Fig. 24-1. When a stone falls to earth, the entropy of the system increases, just as the entropy principle requires.

(c) In the reverse process, heat energy in the amount  $Q = -110 \text{ J}$  would have to be transferred *from* the system of Fig. 24-1b, causing its temperature to *fall* by 5.5 mK. Having acquired this energy in kinetic form, the stone would then leap 2.5 m into the air, restoring the system to that of Fig. 24-1a. The entropy change calculation proceeds just as in (b) except that, because heat is extracted from the system,  $Q$  is now negative and so must be  $\Delta S$ . If this backward process happened, it would have  $\Delta S = -0.37 \text{ J/K}$ , in violation of the entropy principle.

You may be inclined to say, “This ‘backward’ process does not happen because it violates the entropy principle.” A better statement is, “Because we have observed that this backward process—and countless others like it—never happen, scientists have been led to correlate all these observations by formulating the entropy principle.”

**SAMPLE PROBLEM 24-3.** Figure 24-3a shows a paper cup containing a mass  $m = 0.57 \text{ kg}$  of hot water and a similar cup containing an equal mass of cold water. The initial temperature of the hot water is  $T_{\text{IH}} = 90^\circ\text{C} = 363 \text{ K}$ ; that of the cold water is  $T_{\text{IC}} = 10^\circ\text{C} = 283 \text{ K}$ . When the insulating shutter separating the two enclosures is removed, as in Fig. 24-3b, the hot water and the cold water eventually come to thermal equilibrium at a temperature of  $T_f = 50^\circ\text{C} = 323 \text{ K}$ . What is the entropy change of the

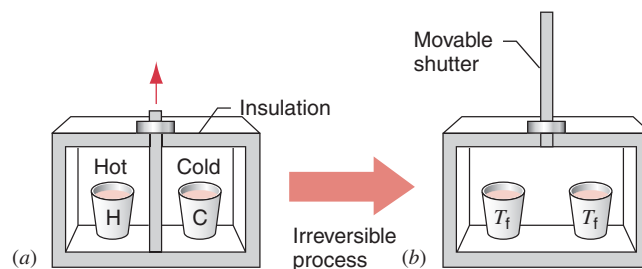

**FIGURE 24-3.** Sample Problem 24-3. (a) In the initial state, two cups of water H and C, identical except for their temperatures, are in an insulating box and are separated by an insulating shutter. (b) When the shutter is removed, the cups exchange heat and come to a final state, both with the same temperature  $T_f$ . The process is irreversible.

system for this irreversible process? The specific heat of water is  $c = 4190 \text{ J/kg} \cdot \text{K}$ ; the heat capacity of the paper cups is negligible.

**Solution** As always, when seeking to find the entropy change for an irreversible process, we must start by finding an equivalent reversible process that connects the same initial and final states. Figure 24-4 shows an arrangement that we can use to carry out such a process.

**Step 1:** Having first adjusted the temperature of the thermal reservoir to  $T_{\text{IH}} = 363 \text{ K}$  we place the cup of hot water (cup H) on it and surround it with a thermally insulating container. We then lower the temperature of the reservoir slowly and reversibly to  $T_f = 323 \text{ K}$ . For each temperature change by an amount  $dT$  during this process, an amount of heat given by  $dQ = mc dT$  is transferred *from* the hot water. From Eq. 24-1, the entropy change of the hot water is

$$\begin{aligned} \Delta S_{\text{H}} &= \int \frac{dQ}{T} = \int_{T_{\text{IH}}}^{T_f} \frac{mc dT}{T} \\ &= mc \ln \frac{T_f}{T_{\text{IH}}} \\ &= (0.57 \text{ kg})(4190 \text{ J/kg} \cdot \text{K}) \ln \frac{323 \text{ K}}{363 \text{ K}} = -279 \text{ J/K}. \end{aligned}$$

Because heat is transferred from the hot water, we expect the entropy change to be negative, as indeed it turns out to be.

**Step 2:** Now put the cup of cold water (cup C) in a similar thermally insulating container, having first adjusted the tempera-

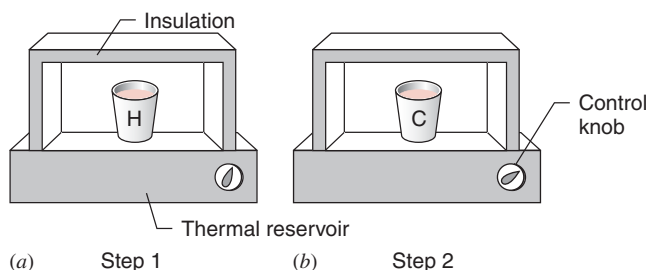

**FIGURE 24-4.** The cups of Fig. 24-3 can proceed from their initial state to their final state in a reversible way if we use a reservoir with a controllable temperature (a) to extract heat reversibly from cup H and (b) to add heat reversibly to cup C.

ture of the thermal reservoir to  $T_{ic} = 283 \text{ K}$ . Then increase the temperature of the reservoir, slowly and reversibly, to  $T_f$ , the final equilibrium temperature of the system. During this process, for every increment of temperature  $dT$  an amount of heat  $dQ = mc dT$  is transferred to the system. The entropy change for the cold water can be calculated as above, the result being

$$\Delta S_C = (0.57 \text{ kg})(4190 \text{ J/kg}\cdot\text{K}) \ln \frac{323 \text{ K}}{283 \text{ K}} = +316 \text{ J/K}.$$

**Step 3:** The net entropy change for the entire system is

$$\begin{aligned} \Delta S &= \Delta S_H + \Delta S_C \\ &= -279 \text{ J/K} + 316 \text{ J/K} = +37 \text{ J/K}. \end{aligned}$$

This is also the entropy change for the irreversible process of Fig. 24-3. Once again we see that the entropy of a closed system *increases* during an irreversible process.

**SAMPLE PROBLEM 24-4.** Let  $n = 0.55 \text{ mol}$  of an ideal gas at room temperature ( $T = 293 \text{ K}$ ) be confined in the left thermally insulated chamber of the apparatus of Fig. 24-5. The right chamber is evacuated and the two chambers—which are of equal volume—are connected by a tube containing a stopcock. If you open the stopcock, the gas will rush to fill the evacuated chamber and will eventually settle down into a state of thermal equilibrium,

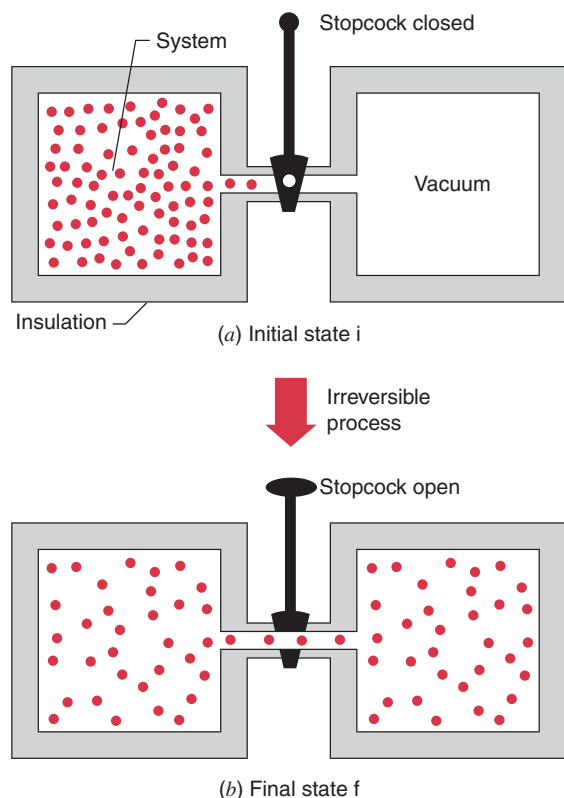

**FIGURE 24-5.** Sample Problem 24-4. The free expansion of an ideal gas. (a) The gas is confined to the left half of an insulated container by a closed stopcock. (b) When the stopcock is opened, the gas rushes to fill the entire container. This process is irreversible; that is, it does not occur in reverse, with the gas spontaneously collecting itself in the left half of the container.

filling both chambers. What is the entropy change of the gas for this irreversible process?

**Solution** The process of Fig. 24-5 is a *free expansion*, a process that we examined in Section 23-8. We learned there that, if the gas is ideal—which we assume—the temperature of the final state is the same as that of the initial state. The free expansion is clearly *not* reversible; we cannot return the system to its previous state by making a small change in its environment.

As in the two previous sample problems, to calculate the entropy change, we must first find an equivalent reversible process that takes the system from the initial state of Fig. 24-5 to its final state. Figure 24-6 shows how such a process can be carried out; it is the reversible isothermal expansion of an ideal gas.

We confine  $0.55 \text{ mol}$  of the gas to an insulated cylinder that rests on a thermal reservoir set to  $T = 293 \text{ K}$ . We place enough lead shot on top of the piston so that the pressure and volume of the gas are those of the initial state of Fig. 24-5a. We then remove the shot very slowly until the pressure and volume of the gas are those of the final state of Fig. 24-5b. This slow process *is* reversible: at each step, we could return a small amount of lead shot to its container, and a corresponding small amount of heat would be transferred to the reservoir *from* the gas. During this expansion process, a total heat energy  $Q$  is transferred *from* the reservoir *to* the gas to maintain the temperature constant as the gas expands.

We can find  $Q$  from the first law of thermodynamics, which we write in differential form as

$$dQ + dW = dE_{\text{int}}.$$

The internal energy of an ideal gas depends only on its temperature (see Eq. 23-24) and, because the temperature does not change ( $dT = 0$ ) we must also have  $dE_{\text{int}} = 0$ . Replacing  $dW$  by  $-p dV$  and substituting  $nRT/V$  for  $p$ , we have

$$dQ = -dW = p dV = nRT \frac{dV}{V}.$$

Integrating between the initial volume and the final volume yields

$$Q = \int dQ = nRT \int_{V_i}^{V_f} \frac{dV}{V} = nRT \ln \frac{V_f}{V_i}.$$

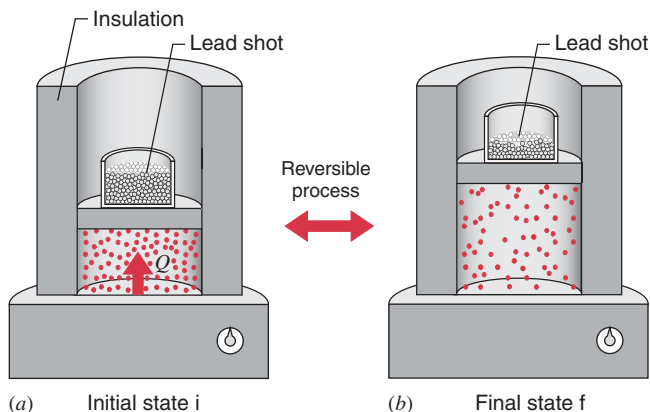

**FIGURE 24-6.** The isothermal expansion of an ideal gas, done in a reversible way. The gas has the same initial state *i* and same final state *f* as in the irreversible process of Fig. 24-5.

We can calculate the entropy change of the isothermal expansion process of Fig. 24-6 from Eq. 24-2, because the temperature is constant throughout. Thus, bearing in mind that  $V_f/V_i = 2$ ,

$$\begin{aligned}\Delta S &= \frac{Q}{T} = nR \ln \frac{V_f}{V_i} \\ &= (0.55 \text{ mol})(8.31 \text{ J/mol} \cdot \text{K})(\ln 2) = +3.17 \text{ J/K}.\end{aligned}$$

This is also the entropy change for the irreversible process of Fig. 24-5. As we expect from the entropy principle, it is positive. We have now provided three examples to demonstrate the entropy increases in irreversible processes that occur in closed systems.

## 24-4 THE SECOND LAW OF THERMODYNAMICS

Before we express the second law of thermodynamics in terms of entropy change, we must solve a little puzzle. We saw in Sample Problem 24-4 that if we cause the gas in Fig. 24-6 to undergo a reversible expansion from (a) to (b) in that figure, the change in entropy of the gas—which we take as our system—is positive. However, because the process is reversible, we can just as easily cause the gas to undergo a reversible compression, making it go from (b) to (a), simply by slowly adding lead shot to the piston of Fig. 24-6b until the original volume of the gas is restored. In this reverse process, heat must be transferred *from* the gas to keep its temperature from rising. Hence  $Q$  is negative and, from Eq. 24-2, so is the entropy change of the gas.

Doesn't this decrease in entropy of the gas violate our expectation that entropy should always increase? No, because the expectation that entropy should always increase holds only for *irreversible* processes occurring in *closed* systems. First, the procedure suggested by Fig. 24-6 is not irreversible. Second, because energy is transferred as heat from the gas to the reservoir, the system (that is, the gas) is not closed.

We can always close a system by enlarging it to include those parts of its environment with which it interacts. In Fig. 24-6, for example, we can choose as our system the *gas + reservoir*, rather than the gas alone. If the process in that figure then goes from (b) to (a), heat  $Q$  moves from the gas to the reservoir—that is, from one part of our larger system to the other. We can calculate the entropy changes of the gas and the reservoir separately with Eq. 24-2, which applies to an isothermal process like that of Fig. 24-6. We get

$$\Delta S_{\text{gas}} = -\frac{|Q|}{T} \quad \text{and} \quad \Delta S_{\text{res}} = +\frac{|Q|}{T},$$

in which  $|Q|$  is the absolute value of the heat transfer, a positive quantity. The entropy change of the closed system *gas + reservoir* is the sum of these two quantities, which is zero. Thus, although the entropy of the gas decreases, that of the reservoir increases, and by the same amount.

With this as background, we can now extend the statement we made in Section 24-1 about entropy changes to include both reversible and irreversible processes. The extended statement, which we call the *second law of thermodynamics*, is:

*When changes occur within a closed system its entropy either increases (for irreversible processes) or remains constant (for reversible processes). It never decreases.*

In equation form this statement becomes

$$\Delta S \geq 0. \quad (24-5)$$

The “greater than” sign applies to irreversible processes and the “equals” sign to reversible processes. No exceptions to the second law of thermodynamics have ever been found.

Although entropy may decrease in part of a closed system, there will always be an equal (or larger) entropy increase in another part of that system so that the entropy of the system as a whole never decreases.

## 24-5 ENTROPY AND THE PERFORMANCE OF ENGINES

A heat engine, or more simply, an *engine*, is a device that extracts energy from its environment in the form of heat and does useful work. At the heart of every engine is a *working substance*. In an automobile engine, for example, the working substance is a gas–air mixture. For an engine to do work on a sustained basis, the working substance must operate in a *cycle*. That is, it must pass through a closed series of thermodynamic processes, returning again and again to any arbitrarily selected state. Let us see what the laws of thermodynamics can tell us about the operation of engines.

### A Carnot Engine

We have seen that we can learn much about real gases by analyzing an ideal gas, which obeys the simple law  $pV = nRT$ . This is a useful plan because, although an ideal gas does not exist, any real gas approaches ideal behavior as closely as you wish if its density is low enough. In much the same spirit we choose to study (real) engines by analyzing the behavior of an ideal engine.

Figure 24-7 shows schematically the operation of our ideal engine. We call it a *Carnot engine*, after the French scientist and engineer N. L. Sadi Carnot (pronounced “car-no”), who first proposed the concept in 1824. It is amazing that Carnot was able to analyze the performance of this engine some 25 years before the first law of thermodynamics was discovered and the concept of entropy was established.

During each cycle of the engine of Fig. 24-7, the working substance absorbs heat  $|Q_H|$  from a reservoir at constant temperature  $T_H$  and discharges heat  $|Q_L|$  to a second

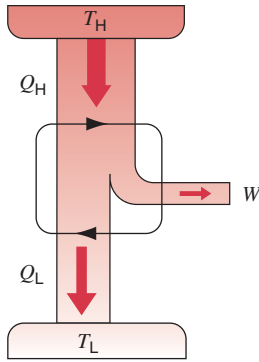
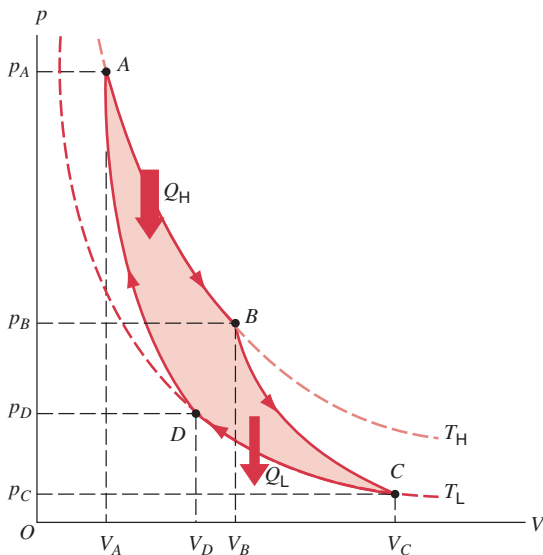

**FIGURE 24-7.** The elements of a Carnot engine. The two black arrowheads on the central loop suggest the working substance operating in a cycle. Heat  $Q_H$  is transferred from the high-temperature reservoir at temperature  $T_H$  to the working substance. Heat  $Q_L$  is transferred from the working substance to the low-temperature reservoir at temperature  $T_L$ . Work  $W$  is done by the engine (actually by the working substance) on something in the environment.

reservoir at a constant lower temperature  $T_L$ . We assume that all thermodynamic processes involved in the operation of the engine are *reversible*, which means that no dissipative processes such as turbulence and friction and no irreversible heat transfers can be present. Although the Carnot engine is a hypothetical engine, we can learn much about real engines by analyzing its performance.

## The Carnot Cycle

Figure 24-8 shows a pressure–volume (or  $pV$ ) plot of the cycle followed by the working substance of the Carnot engine of Fig. 24-7. As indicated by the arrows, the cycle is traversed in the clockwise direction. To carry out the Carnot cycle physically, imagine the working substance of the



**FIGURE 24-8.** The Carnot cycle plotted on a  $pV$  diagram for an ideal gas as the working substance.

Carnot engine to be a gas, confined to an insulating cylinder with a weighted moveable piston. The cylinder may be placed at will on an insulating slab or on either of two thermal reservoirs, one at the high temperature  $T_H$  and the other at the low temperature  $T_L$ . Figure 24-8 shows that, if we place the cylinder in contact with the high-temperature reservoir  $T_H$ , heat  $Q_H$  is transferred *to* the working substance from this reservoir as the gas undergoes an isothermal *expansion* from volume  $V_A$  to volume  $V_B$ . Similarly, with the working substance in contact with the low-temperature reservoir  $T_L$ , heat  $Q_L$  is transferred *from* the working substance to this reservoir, as the gas undergoes an isothermal *compression* from volume  $V_C$  to volume  $V_D$ .

In preparing Fig. 24-7, we have assumed that heat transfers to or from the working substance can take place *only* during the isothermal processes  $AB$  and  $CD$  of Fig. 24-8. Therefore, processes  $BC$  and  $DA$  in that figure, which connect the two isotherms,  $T_H$  and  $T_L$ , must be (reversible) adiabatic processes; that is, they must be processes in which no heat is transferred. To ensure this, during processes  $BC$  and  $DA$  the cylinder is placed on an insulating slab as the volume of the working substance is changed.

As we have defined it (see Section 23-5), work done *on* a gas is negative when the gas expands (its volume increases). In considering the performance of engines, however, we are more interested in the work done *by* the gas on its environment. When the gas expands, it does *positive* work on the environment—for example, it can lift a weight. We continue to define the thermodynamic work  $W$  as we did in Chapter 23 as the work done *on* the gas, but in our discussion of engines we will use  $|W|$  to represent the work done *by* an expanding gas on its environment. This notation reminds us that negative work done *on* the gas corresponds to positive work done *by* the gas.

During the consecutive processes  $AB$  and  $BC$  of Fig. 24-8, the working substance is expanding and thus doing positive work as it raises the weighted piston. This work is represented in Fig. 24-8 by the area under the curve  $ABC$ . During the consecutive processes  $CD$  and  $DA$ , the working substance is being compressed, which means that it is doing negative work on its environment or, equivalently, that its environment is doing positive work on it as the loaded piston descends. This work is represented by the area under the curve  $CDA$ . The *net work per cycle*, which is represented by  $W$  in Fig. 24-7, is the difference between these two areas, a negative quantity equal to the area enclosed by the cycle  $ABCD$  and shown shaded in Fig. 24-8. This work  $W$  is performed on some outside object, perhaps being used to lift a weight.

It is also instructive to plot the Carnot cycle on a temperature–entropy (or  $T$ - $S$ ) diagram, as in Fig. 24-9. Note that, in this plot, the isotherms are horizontal lines. Verify that the points  $A$ ,  $B$ ,  $C$ , and  $D$  in Fig. 24-9 correspond to the points so labeled in the pressure–volume diagram of Fig. 24-8. Figure 24-9 shows that, during process  $AB$ , the entropy of the working substance increases. From Eq. 24-2, this increase is  $|Q_H|/T_H$  because heat  $Q_H$  is transferred to



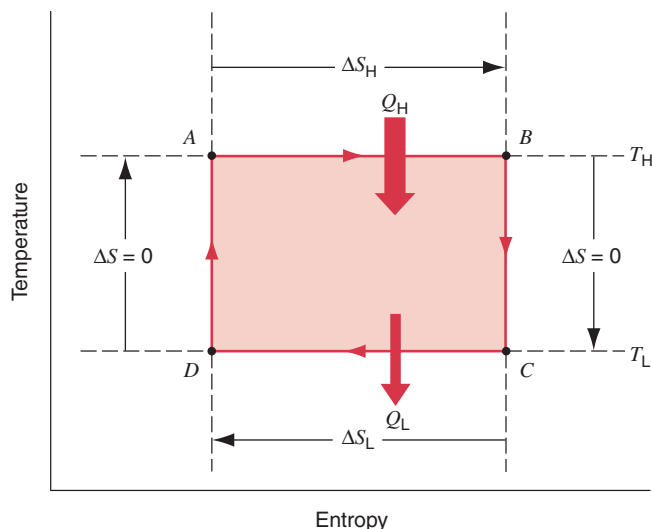

**FIGURE 24-9.** The Carnot cycle shown on a temperature–entropy plot. Entropy changes occur during processes  $AB$  and  $CD$  but not during processes  $BC$  and  $DA$ . The plot will have this rectangular shape regardless of the nature of the working substance.

the working substance, reversibly and at constant temperature  $T_H$ . Similarly, during the process  $CD$  in Fig. 24-9, heat  $Q_L$  is being transferred (reversibly, and at constant temperature  $T_L$ ) from the working substance and, as a result, its entropy decreases. Processes  $BC$  and  $DA$  in Fig. 24-9 are adiabatic; that is, there is no reversible transfer of heat so that, again from Eq. 24-2, the entropy remains constant. Figure 24-9 shows clearly that the Carnot cycle consists of two isothermal processes (in which the temperature remains constant) and two so-called *isentropic* processes (during which the entropy remains constant).

Because the engine operates in a cycle, the working substance must return again and again to any arbitrarily selected state in that cycle. If  $X$  represents any state property of the working substance such as pressure, temperature, volume, internal energy, or entropy, we must have  $\Delta X = 0$  for every cycle. In particular, we must have

$$\Delta E_{\text{int}} = 0 \quad \text{and} \quad \Delta S = 0 \quad (24-6)$$

for every cycle of the working substance. We will use these conclusions later.

### Efficiency of a Carnot Engine

The purpose of an engine is to transform as much of the extracted heat  $Q_H$  into work as possible. We measure its success in doing so by its *thermal efficiency*  $\epsilon$ , defined as the work the engine does per cycle (“what you get”) divided by the heat energy it absorbs per cycle (“what you pay for”), or

$$\epsilon = \frac{\text{energy you get}}{\text{energy you pay for}} = \frac{|W|}{|Q_H|}. \quad (24-7)$$

Let us apply the first law of thermodynamics ( $\Delta E_{\text{int}} = Q + W$ ) to the working substance as it undergoes one cycle

of operation.  $Q$  is then the *net* heat transfer per cycle,  $W$  is the *net* work, and (from Eq. 24-6)  $\Delta E_{\text{int}} = 0$ . That law then becomes

$$|W| = |Q_H| - |Q_L|. \quad (24-8)$$

Combining Eqs. 24-7 and 24-8 yields

$$\epsilon = \frac{|Q_H| - |Q_L|}{|Q_H|} = 1 - \frac{|Q_L|}{|Q_H|}. \quad (24-9)$$

Now let us see what entropy considerations have to say about the operation of a Carnot engine. In this engine, there are two reversible heat transfers and thus two changes in entropy, one ( $\Delta S_H$ ) at temperature  $T_H$  and one ( $\Delta S_L$ ) at  $T_L$ . As Eq. 24-6 reminds us, the net entropy change per cycle must be zero, so that, consistent with Fig. 24-9,

$$\Delta S_H = -\Delta S_L, \quad (24-10)$$

which, because  $\Delta S_L$  is negative, we can write as

$$\frac{|Q_H|}{T_H} = \frac{|Q_L|}{T_L}. \quad (24-11)$$

The quantity on the left is the magnitude of the entropy change at the high-temperature reservoir and that on the right is the magnitude of the entropy change at the low-temperature reservoir. We also see from Eq. 24-11 that, because  $T_H > T_L$ , we must have  $|Q_H| > |Q_L|$ . That is, more energy is extracted as heat from the high-temperature reservoir than is delivered to the low-temperature reservoir.

Combining Eqs. 24-9 and 24-11, we obtain the efficiency of a Carnot engine:

$$\epsilon = 1 - \frac{T_L}{T_H} \quad (\text{Carnot efficiency}). \quad (24-12)$$

Because  $T_L < T_H$ , the Carnot engine necessarily has a thermal efficiency less than unity—that is, less than 100%. We can see this from Fig. 24-7, which shows that only part of the heat energy extracted from the high-temperature reservoir is available to do work, the rest being delivered to the low-temperature reservoir. We will show in Section 24-7 that *no real engine can have a thermal efficiency greater than that calculated from Eq. 24-12*.

Note that, in deriving Eq. 24-12, we did not need to specify the nature of the working substance, nor did we do so. We conclude:

*Equation 24-12 gives the efficiency of all Carnot engines working between the same two fixed temperatures, regardless of the nature of their working substance.*

### Search for a “Perfect” Engine

Inventors continually try to improve engine efficiency by reducing the energy  $|Q_L|$  that is “thrown away” during each cycle. The inventor’s dream is to produce the *perfect engine*, diagrammed in Fig. 24-10, in which  $Q_L$  is reduced to zero and  $Q_H$  is converted completely into work. Such an engine on an ocean liner, for example, could extract heat from

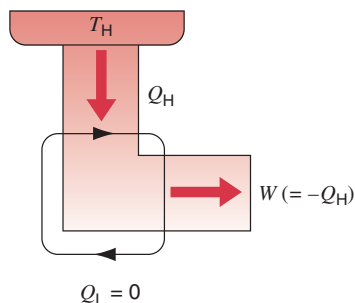

**FIGURE 24-10.** The elements of a perfect engine—that is, one that converts heat  $Q_H$  from a high-temperature reservoir directly to work  $W$  with 100% efficiency.

the ocean and use it to drive the propellers, with no fuel cost. An automobile, fitted with such an engine, could extract heat energy from the surrounding air and use it to drive the car, again with no fuel cost. Alas, a perfect engine is only a dream! Inspection of Eq. 24-12 shows that we can achieve 100% engine efficiency (that is,  $\epsilon = 1$ ) only if  $T_L = 0$  or  $T_H \rightarrow \infty$ , requirements that are impossible to meet. Instead, decades of practical engineering experience have led to the following alternative version of the second law of thermodynamics:

*No series of processes is possible whose sole result is the absorption of heat from a thermal reservoir and the complete conversion of this energy to work.*

In short, *there are no perfect engines.*

To summarize: the thermal efficiency given by Eq. 24-12 applies only to Carnot engines. Real engines, in which the processes that form the engine cycle are not reversible, have lower efficiencies. If your car were powered by a Carnot engine, it would have an efficiency of about 55% according to Eq. 24-12; its actual efficiency is probably about 25%. A nuclear power plant, taken in its entirety, is an engine. Its high-temperature reservoir is the reactor core and its low-temperature reservoir is a nearby river. Work is done on a steam turbine, which drives an alternator, generating electrical power. If a nuclear power plant operated as a Carnot engine, its efficiency would be about 40%; its actual efficiency is about 30%. In designing engines of any type, there is simply no way to overcome the efficiency limitation imposed by Eq. 24-12.

## Other Reversible Engines

Equation 24-12 does not apply to all reversible engines, but only to engines that have two (and only two) thermal reservoirs, as in Fig. 24-7. In short, it applies only to Carnot engines. For example, Fig. 24-11 shows the operating cycle of an ideal (that is, reversible) *Stirling engine*. Comparison with the Carnot cycle of Fig. 24-8 shows that each engine has isothermal heat transfers at temperatures  $T_H$  and  $T_L$ . However, the two isotherms of the Stirling engine cycle of Fig. 24-11 are connected, not by adiabatic processes as for

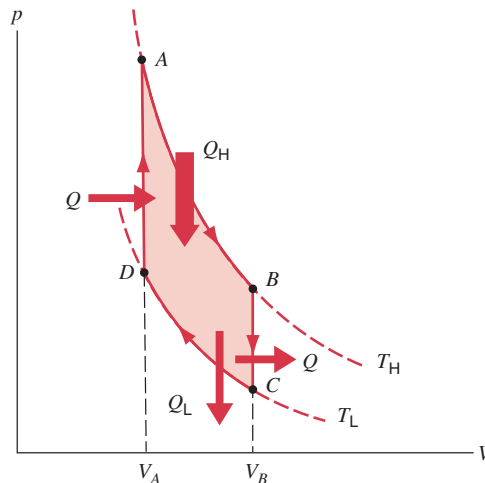

**FIGURE 24-11.** A  $pV$  plot for the working substance of an ideal (that is, reversible) Stirling engine, assumed for convenience to be an ideal gas. Compare the Carnot engine cycle of Fig. 24-8. Each cycle has two isothermal processes, but in the Stirling engine these processes are connected by two constant-volume (not constant-entropy) processes, along which heat transfers also occur.

the Carnot engine, but by constant-volume processes. To increase the temperature of a gas at constant volume reversibly from  $T_L$  to  $T_H$  (as in process  $DA$  of Fig. 24-11) requires a heat transfer to the working substance from a thermal reservoir whose temperature can be varied smoothly between those limits. Although reversible heat transfers (and corresponding entropy changes) occur in only two of the processes that form the cycle of a Carnot engine, they occur in all four of the processes that form the cycle of a Stirling engine. All four heat exchanges must be taken into account in deriving the thermal efficiency of a Stirling engine. Its efficiency will be lower than that of a Carnot engine operating between the same two temperatures. Real Stirling engines, in contrast to ideal Stirling engines, will have still lower efficiencies.

**SAMPLE PROBLEM 24-5.** The turbine in a steam power plant takes steam from a boiler at  $520^\circ\text{C}$  and exhausts it to a condenser at  $100^\circ\text{C}$ . What is the maximum possible efficiency of the turbine?

**Solution** The maximum efficiency is that of a Carnot engine operating between the same two temperatures or, from Eq. 24-12,

$$\begin{aligned}\epsilon_{\max} &= 1 - \frac{T_L}{T_H} = 1 - \frac{(273 + 100) \text{ K}}{(273 + 520) \text{ K}} \\ &= 0.53 \quad \text{or} \quad 53\%\end{aligned}$$

Note that the temperatures in Eq. 24-12 *must* be expressed in kelvins. Because of friction, turbulence, and unwanted heat transfers, actual efficiencies of about 40% may be realized for a turbine of this type. Note that the theoretical maximum efficiency depends *only* on the two temperatures involved, not on the pressures or other factors.

## 24-6 ENTROPY AND THE PERFORMANCE OF REFRIGERATORS

A *refrigerator* is a device that uses work to transfer thermal energy from a low-temperature reservoir to a high-temperature reservoir as it continuously repeats a set series of thermodynamic processes. In a household refrigerator, for example, work is done by an electrical compressor to transfer thermal energy from the food storage compartment (a low-temperature reservoir) to the room (a high-temperature reservoir).

An *air conditioner* is a refrigerator. Its low-temperature reservoir is the room that is to be cooled, and its high-temperature reservoir is the (presumably warmer) outdoors. A *heat pump*, which is also a refrigerator, is an air conditioner that can be operated in reverse to heat a room. The room is now the high-temperature reservoir and heat is transferred to it from the (presumably cooler) outdoors.

Figure 24-12 shows the basic elements of a refrigerator. If we assume that the processes involved in the operation of the refrigerator are reversible, then we have an *ideal refrigerator*. Comparison of Fig. 24-12 with Fig. 24-7 shows that an ideal refrigerator is simply a Carnot engine running backward, with the directions of all energy transfers, either as heat or work, reversed. Thus we call the ideal refrigerator of Fig. 24-12 a *Carnot refrigerator*.

The designer of a refrigerator would like to extract as much heat  $|Q_L|$  as possible from the low-temperature reservoir (“what you want”) for the least amount of work (“what you pay for”). We take, as a measure of the efficiency of a refrigerator, the ratio

$$K = \frac{\text{what you want}}{\text{what you pay for}} = \frac{|Q_L|}{|W|}. \quad (24-13)$$

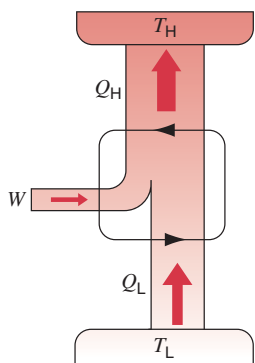

**FIGURE 24-12.** The elements of a Carnot refrigerator. The two black arrowheads on the central loop suggest the working substance operating in a cycle, as if on a  $pV$  plot. Heat  $Q_L$  is transferred to the working substance from the low-temperature reservoir. Heat  $Q_H$  is transferred to the high-temperature reservoir from the working substance. Work  $W$  is done on the refrigerator (on the working substance) by something in the environment.

The larger the value of  $K$ , called the *coefficient of performance*, the more efficient is the refrigerator.

The first law of thermodynamics, applied to the working substance of the refrigerator, yields

$$|W| = |Q_H| - |Q_L|$$

so that Eq. 24-13 becomes

$$K = \frac{|Q_L|}{|Q_H| - |Q_L|}. \quad (24-14)$$

Because a Carnot refrigerator is simply a Carnot engine working backward, Eq. 24-11 holds for it. If we combine that equation with Eq. 24-14 we find, after a little algebra,

$$K = \frac{T_L}{T_H - T_L} \quad (\text{Carnot refrigerator}). \quad (24-15)$$

For a typical room air conditioner,  $K \approx 2.5$ , which means (see Eq. 24-13) that the unit removes 2.5 J of thermal energy from the room for every joule of electrical energy supplied to it. As Eq. 24-15 shows, the value of  $K$  becomes larger as the temperatures of the two reservoirs become more nearly the same. That is why heat pumps are more effective in temperate climates than in climates where the outside temperature fluctuates between wide limits.

### Search for a “Perfect” Refrigerator

It would be nice to own a refrigerator that did not require some input of work—that is, one that would run without being plugged in. Figure 24-13 shows another “inventor’s dream,” a *perfect refrigerator*, for which  $W = 0$ , so that (see Eq. 24-13)  $K \rightarrow \infty$ . However, as we shall now see, such a device would violate the second law of thermodynamics.

Let us take as our system the working substance and also the two heat reservoirs. Only by including the reservoirs can we ensure that the system is closed. Because the unit operates in a cycle, the entropy of the working substance does not change during one cycle. The entropies of

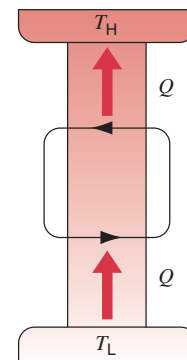

**FIGURE 24-13.** The elements of a perfect refrigerator—that is, one that transfers heat from a low-temperature reservoir to a high-temperature reservoir without any input of work.

the two reservoirs, however, do change, the net entropy change for the entire closed system (see Fig. 24-13) being

$$\Delta S = -\frac{|Q|}{T_L} + \frac{|Q|}{T_H},$$

in which heat  $Q$  leaves the low-temperature reservoir and, in the same amount, enters the high-temperature reservoir. Because  $T_H > T_L$ , the net change in entropy per cycle for a perfect refrigerator would be negative, a violation of the second law of thermodynamics. If you want your refrigerator to work, you must plug it in!

This result leads to a third equivalent formulation of the second law of thermodynamics, often called the Clausius version, after Rudolph Clausius (1822–1888) who first introduced the concept of entropy:

*No process is possible whose sole result is the transfer of heat from a reservoir at one temperature to another reservoir at a higher temperature.*

In short, *there are no perfect refrigerators.*

**SAMPLE PROBLEM 24-6.** A household refrigerator, whose coefficient of performance  $K$  is 4.7, extracts heat from the food chamber at the rate of 250 J/cycle. (a) How much work per cycle is required to operate the refrigerator? (b) How much heat per cycle is discharged to the room?

**Solution** (a) The basic definition of coefficient of performance, Eq. 24-13, relates  $K$  to the work done and the heat  $Q_L$  removed from the low-temperature reservoir. Solving that equation for  $W$  yields

$$|W| = \frac{|Q_L|}{K} = \frac{250 \text{ J/cycle}}{4.7} = 53 \text{ J/cycle}.$$

(b) Applying the first law of thermodynamics to the working substance of the refrigerator yields

$$-|Q_H| + |Q_L| + |W| = \Delta E_{\text{int}}.$$

Here  $\Delta E_{\text{int}} = 0$  because the working substance operates in a cycle. Solving the above equation for  $|Q_H|$  and inserting the known data yields

$$\begin{aligned} |Q_H| &= |W| + |Q_L| \\ &= 53 \text{ J/cycle} + 250 \text{ J/cycle} = 303 \text{ J/cycle}. \end{aligned}$$

We see that the refrigerator is an efficient room heater. By paying for 53 J of energy (to run the compressor) we get 303 J of heat energy delivered to the room. If we heated the room with an electric heater, we would get only 53 J of heat energy for every 53 J of work we paid for.

**SAMPLE PROBLEM 24-7.** A heat pump is a device that—acting as a refrigerator—can heat a house by transferring heat energy from the outside to the inside of the house; the process is driven by work done on the device. The outside temperature is  $-10^\circ\text{C}$ , and the interior is to be kept at  $22^\circ\text{C}$ . To maintain the temperature by making up for normal heat losses it is necessary to deliver heat to the interior at the rate of 16 kW. At what minimum rate must energy be supplied to the heat pump?

**Solution** The low-temperature reservoir is the great outdoors, at  $T_L = (273 - 10) = 263 \text{ K}$ , and the high-temperature reservoir is the house interior at  $T_H = (273 + 22) = 295 \text{ K}$ . The maximum coefficient of performance of a heat pump is given by Eq. 24-15, or

$$K = \frac{T_L}{T_H - T_L} = \frac{263 \text{ K}}{295 \text{ K} - 263 \text{ K}} = 8.22.$$

Applying the first law of thermodynamics to Eq. 24-13 yields

$$K = \frac{|Q_L|}{|W|} = \frac{|Q_H| - |W|}{|W|}.$$

Solving for  $|W|$  and dividing by  $\Delta t$ , the duration of a cycle, to express the result in terms of power yields

$$|W/\Delta t| = \frac{|Q_H/\Delta t|}{K + 1} = \frac{16 \text{ kW}}{8.22 + 1} = 1.7 \text{ kW}.$$

Herein lies the “magic” of the heat pump. By using the heat pump as a refrigerator to heat a house by cooling the great outdoors, you can deliver 16 kW to the interior of the house as heat but you need pay for only the 1.7 kW it takes to run the pump.

Actually, the 1.7 kW is a theoretical minimum because it is based on the assumption that the heat pump is a Carnot refrigerator. In practice, a greater power input would be required but there would still be a very considerable saving over, say, heating the house directly with electric heaters.

## 24-7 THE EFFICIENCIES OF REAL ENGINES

In this section we wish to show that no real engine can have an efficiency greater than that of a Carnot engine operating between the same two temperatures. That is, no real engine can have an efficiency greater than that given by Eq. 24-12.

Let us assume that an inventor has constructed an engine, engine X, whose efficiency  $\epsilon_X$ —it is claimed—is greater than  $\epsilon_C$ , the efficiency of a Carnot engine. That is,

$$\epsilon_X > \epsilon_C \quad (\text{a claim}). \quad (24-16)$$

Let us couple engine X to a Carnot refrigerator, as in Fig. 24-14a. We adjust the strokes of the Carnot refrigerator so that the work it requires per cycle is just equal to that provided by engine X. Thus no (external) work is performed on or by the combination *engine + refrigerator* of Fig. 24-14a, which we take as our system.

If Eq. 24-16 is true then, from the definition of efficiency (see Eq. 24-7), we must have

$$\frac{|W|}{|Q_{\text{HX}}|} > \frac{|W|}{|Q_{\text{HC}}|}.$$

Here  $Q_{\text{HX}}$  is the heat extracted from the high-temperature reservoir by engine X and  $Q_{\text{HC}}$  is that same quantity for the Carnot refrigerator when it operates as an engine. This inequality requires that

$$|Q_{\text{HC}}| > |Q_{\text{HX}}|. \quad (24-17)$$

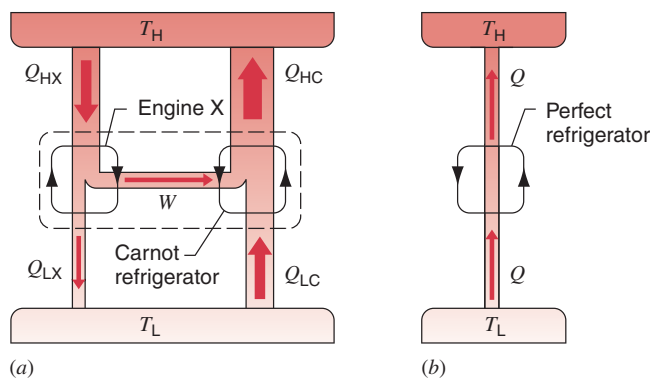

**FIGURE 24-14.** (a) Engine X drives a Carnot refrigerator. If engine X were more efficient than a Carnot engine, then the combination would be equivalent to the perfect refrigerator shown in (b).

Now let us apply the first law of thermodynamics separately to the working substances of the Carnot refrigerator and also that of engine X. Because we have chosen the work done by engine X to be equal to the work done on the Carnot refrigerator, we have

$$|W| = |Q_{HC}| - |Q_{LC}| = |Q_{HX}| - |Q_{LX}|,$$

which we can write as

$$|Q_{HC}| - |Q_{HX}| = |Q_{LC}| - |Q_{LX}| = Q. \quad (24-18)$$

Because of Eq. 24-17, the quantity  $Q$  in Eq. 24-18 must be positive.

Comparison of Eq. 24-18 with Fig. 24-14 shows that the net effect of engine X and the Carnot refrigerator, working in combination, is to transfer heat energy  $Q$  from a low-temperature reservoir to a high-temperature reservoir without the requirement of work; see Fig. 24-14b. Thus the combination acts like the perfect refrigerator of Fig. 24-13, whose existence is a violation of the second law of thermodynamics.

Something must be wrong. We conclude that the claim made in Eq. 24-16 cannot be correct and

*No real engine can have an efficiency greater than that of a Carnot engine working between the same two temperatures.*

At most, a real engine can have an efficiency equal to the Carnot engine efficiency, given by Eq. 24-12. In that case, of course, engine X *is itself* a Carnot engine. Because real engines are irreversible, their efficiencies will always be less than the limit set by Eq. 24-12.

**SAMPLE PROBLEM 24-8.** The inventor of engine X claims that it has a work output  $W = 120$  J per cycle and operates between the boiling and freezing points of water with an efficiency of  $\epsilon_X = 75\%$  (a) How does this claimed efficiency compare with the efficiency of a Carnot engine operating between the same two temperatures? (b) If engine X actually existed, how much heat energy  $Q_H$  would it extract from the high-temperature reservoir per cycle? (c) If engine X actually existed, how much

heat energy  $Q_L$  would it discharge to the low-temperature reservoir per cycle? (d) Once more, assuming that engine X actually exists, what would be the entropy change per cycle for the entire engine, including the working substance and both reservoirs?

**Solution** (a) From Eq. 24-12, which applies only to a Carnot engine, we have

$$\begin{aligned} \epsilon_c &= 1 - \frac{T_L}{T_H} \\ &= 1 - \frac{(273 + 0) \text{ K}}{(273 + 100) \text{ K}} = 0.268 \approx 27\%. \end{aligned}$$

As we have shown in this section, no real engine can have an efficiency greater than that of a Carnot engine operating between the same two temperatures. Regardless of the inventor's claim, engine X must have an efficiency less than 27%. Something is wrong.

(b) From Eq. 24-7 we have

$$|Q_H| = \frac{|W|}{\epsilon_X} = \frac{120 \text{ J}}{0.75} = 160 \text{ J}.$$

(c) Applying the first law of thermodynamics to the working substance of engine X yields

$$|W| = |Q_H| - |Q_L|.$$

(Because the working substance operates in a cycle,  $\Delta E_{\text{int}} = 0$ .) Solving the above equation for  $Q_L$  and substituting numerical data yields

$$|Q_L| = |Q_H| - |W| = 160 \text{ J} - 120 \text{ J} = 40 \text{ J}.$$

(d) The system we have chosen is closed so that we can apply the second law of thermodynamics in the form of Eq. 24-5. Bearing in mind that, because the engine operates in a cycle, the entropy change per cycle of its working substance is zero, we have

$$\begin{aligned} \Delta S_X &= \Delta S_H + \Delta S_L + \Delta S_{\text{WS}} \\ &= -\frac{|Q_H|}{T_H} + \frac{|Q_L|}{T_L} + 0 \\ &= -\frac{160 \text{ J}}{(273 + 100) \text{ K}} + \frac{40 \text{ J}}{(273 + 0) \text{ K}} + 0 \\ &= -0.429 \text{ J/K} + 0.147 \text{ J/K} + 0 = -0.28 \text{ J/K}. \end{aligned}$$

The terms on the right are, respectively, the entropy changes of the high-temperature reservoir (a negative quantity), of the low-temperature reservoir (a positive quantity), and of the working substance.

Note that, as we expect, the entropy of engine X *decreases* steadily ( $\Delta S_X < 0$ ) as the cycles progress. This is a clear violation of the second law, which states that the entropy of a closed system can never decrease. Once again, something is wrong.

## 24-8 THE SECOND LAW REVISITED

So far we have presented three statements of the second law of thermodynamics as it applies to closed systems, namely:

**1.** The entropy of such systems never decreases. That is, as Eq. 24-5 shows,  $\Delta S \geq 0$ .

2. You cannot change heat energy into work with 100% efficiency. That is, there are no perfect engines.

3. You cannot transfer heat energy from a low-temperature reservoir to a higher temperature reservoir without doing work. That is, there are no perfect refrigerators.

At first glance these statements seem quite different. However, they are all completely equivalent. If you accept any one of these statements, you must also accept the other two. If any one of them is false, the other two are also false.

In Section 24-5 we showed that statement 2 follows from statement 1 and in Section 24-6 we showed that statement 3 also follows from statement 1. Here we will show that statements 2 and 3 are completely equivalent.

Consider what could happen if statement 2 were false and we could actually build a perfect engine, converting heat  $Q_H$  entirely into work  $W$ . Let us use this work output to drive a Carnot refrigerator, as shown in Fig. 24-15a. This refrigerator transfers heat  $|Q_{HC}| = |Q_{LC}| + |W|$  into the high-temperature reservoir.

Let us regard the combination of the perfect engine and the Carnot refrigerator as a single device, as shown by the dashed boundary lines in Fig. 24-15a. The work  $W$  is an internal feature of this device and does not represent an exchange of energy between the device and its environment. The overall effect of the combined device is to take heat  $|Q_{LC}|$  from the low-temperature reservoir and deliver to the high-temperature reservoir a net amount of heat equal to  $|Q_{HC}| - |Q_H|$ . However,  $|Q_H| = |W|$ , so, applying the first law of thermodynamics to the Carnot refrigerator,

$$|Q_{HC}| - |Q_H| = |Q_{HC}| - |W| = |Q_{LC}|.$$

Thus, as Fig. 24-15b shows, our combined device acts like a perfect refrigerator, taking heat  $|Q_{LC}|$  from the low-temperature reservoir and transferring it to the high-temperature reservoir, with no external work performed.

Thus, if you can build a perfect engine, you can also build a perfect refrigerator. By a similar argument, you can show that, if you can build a perfect refrigerator, you can also build a perfect engine. Thus, a violation of statement 2 of the second law above implies a violation of statement 3, and conversely. The two statements are logically equivalent.

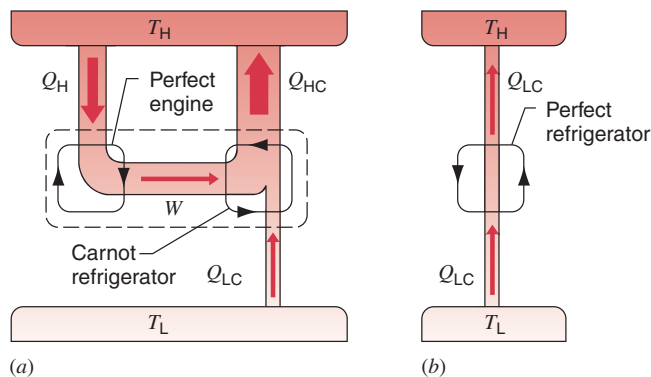

**FIGURE 24-15.** (a) A Carnot refrigerator, driven by a perfect engine, is equivalent to (b) a perfect refrigerator.

## 24-9 A STATISTICAL VIEW OF ENTROPY

In our discussion of entropy so far we have said nothing about the fact that matter is made up of atoms. In this section we take that fact as central and we will see that we can approach the entropy concept from that direction. We start with the simple problem of counting the number of ways that we can divide a small number of atoms (for generality, we will call them molecules) between the two halves of a box. This is a problem in the general field of *statistical mechanics*.

Imagine that we distribute—by hand—eight molecules between the two halves of a box. The molecules are indistinguishable so we can pick the first one to put in the box in eight different ways. We then have seven choices for the second molecule, six choices for the third, and so on. The total number of ways in which we can put the eight molecules in the box is the product of these independent choices, or

$$8 \times 7 \times 6 \times 5 \times 4 \times 3 \times 2 \times 1 = 40,320.$$

We write this in mathematical shorthand as

$$8! = 40,320,$$

in which  $8!$  is pronounced “eight factorial.” Your calculator can probably calculate factorials for you. By definition, we take  $0! = 1$ , a fact that we will use later.

However, not all of these 40,320 ways are independent. We have overcounted and that number is too large. Consider the *configuration* of Fig. 24-16a, for example, in which there happen to be five molecules in one half of the box and three in the other. Because the molecules are identical, there is no way that, simply by looking at the five

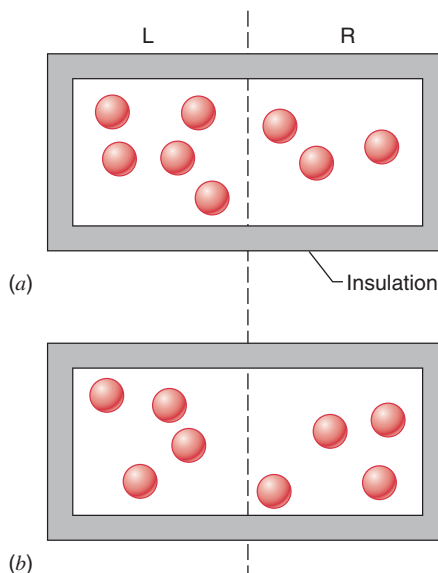

**FIGURE 24-16.** An insulated box contains eight gas molecules. Each molecule has the same probability of being in the left half (L) of the box as in the right half (R). The arrangement in (a) corresponds to configuration IV in Table 24-1, and that in (b) corresponds to configuration V.

molecules, we can deduce the order in which we put them there. We can, in fact, put these five molecules in place in  $5 \times 4 \times 3 \times 2 \times 1 = 5! = 120$  different ways, all leading to the same configuration. Similarly, we can put the three molecules in the other half of the box in  $3 \times 2 \times 1 = 3! = 6$  different ways.

To get the number of truly independent ways of arriving at the configuration of Fig. 24-16a, we need to divide 40,320 by 120 and also by 6, obtaining 56. We call each of these 56 ways a *microstate* of the configuration and we call the number of microstates that lead to a given configuration the *multiplicity*  $w$  of that configuration. Thus the configuration of Fig. 24-16a has a multiplicity of 56, which means that it contains 56 microstates.

Extending our consideration from eight molecules to  $N$  molecules, the multiplicity of the configuration in which  $N_1$  molecules are in one half of the box and  $N_2$  in the other is given by

$$w = \frac{N!}{N_1! N_2!}. \quad (24-19)$$

We can use this general relation to verify that, for eight molecules ( $N = 8$ ), the multiplicity of the configuration of Fig. 24-16a ( $N_1 = 5, N_2 = 3$ ) is indeed 56.

Table 24-1 shows that, for eight molecules, there are nine configurations, which we have labeled with Roman numerals. The multiplicities, calculated from Eq. 24-19, are also shown. We see that Fig. 24-16a shows configuration IV and Fig. 24-16b shows configuration V. The total number of microstates of the eight-molecule system is 256 ( $= 2^8$ ).

The basic assumption of our statistical approach to thermodynamics is perhaps a surprising one; namely,

*All microstates of a system are equally probable.*

Thus, as the eight molecules in the system of Fig. 24-16 jostle around in their random fashion, the system will spend, on average, the same amount of time in each of the 256 microstates listed in Table 24-1. Note that all *configurations* are *not* equally probable. In fact, the system will spend 70 times longer in configuration V than in configuration I, because configuration V includes 70 times as many

microstates. Configuration V is clearly the most favored configuration, with the greatest probability of occurrence. This begins to be familiar, reminding us that in thermal equilibrium we are likely to find the molecules of a gas uniformly distributed throughout the volume of their container.

Eight molecules in a box ( $N = 8$ ) are not very many on which to base a conclusion about the real world. Let us increase the number  $N$  to 50 (still a small number!) and again compare the length of time in which 25 molecules are in each half of the box to that in which all the molecules are in a given half of the box. The ratio is not 70 to 1 (as it is for  $N = 8$  in Table 24-1) but about  $1.2 \times 10^{14}$  to 1. If you could count the microstates for the configuration  $N_1 = N_2 = 25$  at the rate of one per second, it would take you about four million years to complete the task! Imagine how many microstates there are for the much more reasonable case of  $N \approx 10^{22}$ , which is about the number of air molecules in a child's balloon. The probability is then completely overwhelming for an even distribution of molecules between the two halves of the box.

For large values of  $N$ , nearly all the microstates correspond to an essentially equal division of the molecules between the two halves of the box, as Fig. 24-17 indicates. Even though the measured temperature and pressure of the gas remain constant, at the molecular level the gas is churning away endlessly, its molecules "visiting" all the possible microstates with equal probabilities. However, so few microstates lie outside the narrow central peak of Fig. 24-17 that the gas molecules can be considered always to be evenly divided between the two halves of the box. There is a chance that all of the molecules will find themselves in one half of the box but, for large numbers of molecules, it is a vanishingly small one.

**TABLE 24-1** Eight Molecules in a Box

Configuration	$N_1$	$N_2$	Multiplicity <sup>a</sup> $w$	Entropy ( $10^{-23}$ J/K) <sup>b</sup>
I	8	0	1	0
II	7	1	8	2.87
III	6	2	28	4.60
IV	5	3	56	5.56
V	4	4	70	5.86
VI	3	5	56	5.56
VII	2	6	28	4.60
VIII	1	7	8	2.87
IX	0	8	1	0
Total number of microstates			256	

<sup>a</sup> Calculated from Eq. 24-19

<sup>b</sup> Calculated from Eq. 24-20

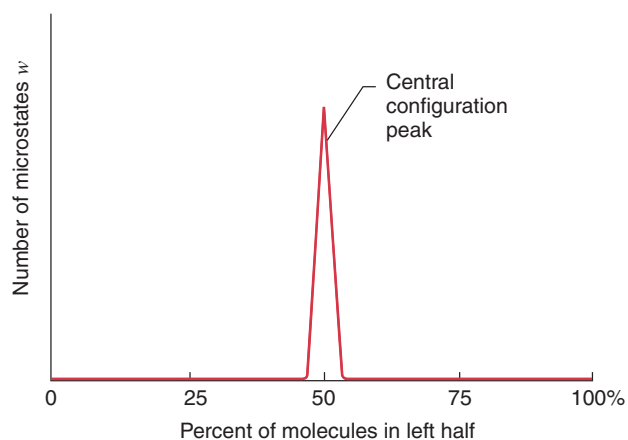

**FIGURE 24-17.** For a *large* number of molecules in a box, a plot of the number of microstates that require various percentages of the molecules to be in the left half of the box. Nearly all the microstates correspond to an approximately equal sharing of the molecules between the two halves of the box; those microstates form the central *configuration peak* on the plot. For  $N \approx 10^{22}$ , the central configuration peak would be much too narrow to be drawn on this plot.

We see that, left to themselves, systems tend toward configurations with the highest value of  $w$ —that is, toward configurations with the highest probability of occurrence. We have also seen that systems tend toward configurations with the greatest entropy. There must be a relationship between probability and entropy. Any such relationship must take into account these two facts:

1. The probability of occurrence of two subsystems is the *product* of their individual probabilities.

2. The entropy of a system consisting of two subsystems is the *sum* of their individual entropies.

That is, probabilities (as for coin tossing) are multiplicative and entropies (as for energies or volumes) are additive.

This suggests that the relationship between entropy and probability must involve a logarithm because that is a simple way (and, indeed, it is the only way) in which quantities that are multiplied are related to quantities that are added. Thus,

$$\ln(a \times b) = \ln a + \ln b.$$

The Austrian physicist Ludwig Boltzmann first pointed out the relationship between entropy and probability in 1877, by advancing the logarithmic relation, now called *Boltzmann's entropy equation*,

$$S = k \ln w, \quad (24-20)$$

in which  $k (= 1.38 \times 10^{-23} \text{ J/K})$  is the Boltzmann constant that we first encountered in Section 21-5 and  $w$  is the multiplicity associated with the configuration whose entropy  $S$  we wish to calculate. We have used Eq. 24-20 to calculate the entropy of the nine configurations of Table 24-1.

In using Eq. 24-19 to calculate  $w$ , a problem may arise in that your calculator will flash an overflow signal if you try to find the factorial of a number much greater than a few hundred—still a very small number where macroscopic systems are concerned. Fortunately, there is a very good approximation (known as *Stirling's approximation*) not for  $N!$  but for  $\ln N!$ . As Eqs. 24-19 and 24-20 show,  $\ln N!$  is just what we need to calculate the entropy. Stirling's approximation is

$$\ln N! \approx N \ln N - N. \quad (24-21)$$

(Incidentally, the Stirling of the approximation and the Stirling whose engine we described in Fig. 24-11 are not the same person.)

## Entropy and Disorder

Boltzmann's entropy equation (Eq. 24-20) can be used to calculate the entropy of thermodynamic systems much more complex than the simple one we have examined—namely, the distribution of molecules between the two halves of a box. Let us apply it qualitatively—for example, to the observation that a stirred cup of coffee, swirling in its cup, will eventually stop swirling and come to rest. We will focus our attention, not on the positions of the molecules (as we did for the molecules-in-a-box problem) but on their velocities.

The final resting state, in which the velocities of the molecules are randomly directed, contains many more microstates than does the initial state, in which the velocities of most molecules are pointed in or near the direction of swirl. Put another way, there are many more ways that you could assign velocities to the molecules to produce a resting cup of coffee than to produce a swirling cup of coffee. That is,

$$w_{\text{resting}} > w_{\text{swirling}}.$$

From Eq. 24-20 it then follows that

$$S_{\text{resting}} > S_{\text{swirling}}.$$

According to the second law of thermodynamics, the coffee—left to itself—will change spontaneously in the direction in which its entropy increases. It will never change in the opposite direction. That is, the “natural” behavior is from swirling to resting. A resting cup of coffee will never start to swirl all by itself.

Entropy is often associated with *disorder* and the second law of thermodynamics is sometimes cast as a statement that the disorder of a closed system always increases. This seems clear enough for our swirling cup of coffee. The final state, with the randomly directed motions of its molecules, is more disordered than the initial state, with the directed motions of a substantially large number of its molecules. In general, however, the association of entropy with disorder requires a careful definition of disorder, appropriate to the process at hand. Responding to the order evident in much of our life experience—including life itself—the physicist and science writer Timothy Ferris, perhaps pushing the concept to a limit, has written

“Entropy can decrease locally even while it increases on the cosmic scale. One might go so far as to say that the excitement generated by life, art, science, and the spectacle of a bustling city with its libraries and theaters is at root the excitement of seeing the law of entropy being defeated—in one place at least, for a while.”

**SAMPLE PROBLEM 24-9.** (a) In how many independent ways can 200 molecules be divided evenly between the two halves of a box? (b) How many microstates are there that correspond to 150 molecules in one half of the box and 50 in the other?

**Solution** (a) In this problem we have  $N = 200$  and  $N_1 = N_2 = 100$ . From Eq. 24-19,

$$\begin{aligned} w &= \frac{N!}{N_1! N_2!} \\ &= \frac{200!}{100! 100!} = \frac{2.22 \times 10^{373}}{(3.72 \times 10^{156})(3.72 \times 10^{156})} \\ &= 1.60 \times 10^{60}. \end{aligned}$$

Note how large the factorials are. You can calculate them on a hand calculator using Stirling's approximation (Eq. 24-21).

(b) In this case,  $N = 200$ ,  $N_1 = 150$ , and  $N_2 = 50$ . Again using Eq. 24-19 we have



$$\begin{aligned}
 w &= \frac{N!}{N_1! N_2!} \\
 &= \frac{200!}{(150!)(50!)} = \frac{2.22 \times 10^{373}}{(1.86 \times 10^{261})(1.71 \times 10^{63})} \\
 &= 6.97 \times 10^{48}.
 \end{aligned}$$

By dividing these two multiplicities, you can learn that the 100/100 split is about 200 billion times more likely than the 150/50 split. As  $N$  increases, the  $N_1 = N_2$  split comes to dominate, as Fig. 24-17 shows.

## MULTIPLE CHOICE

### 24-1 One-Way Processes

#### 24-2 Defining Entropy Change

- For which of the following processes is the entropy change zero?
  - Isobaric
  - Isothermal
  - Adiabatic
  - Constant volume
  - None of these, since  $\Delta S > 0$  for all processes.
- One mole of an ideal gas is originally at  $p_0$ ,  $V_0$ , and  $T_0$ . The gas is heated at constant volume to  $2T_0$ , then allowed to expand at constant temperature to  $2V_0$ , and finally it is allowed to cool at constant pressure to  $T_0$ . The net entropy change for this ideal gas is
  - $\Delta S = (5R/2) \ln 2$ .
  - $\Delta S = 5R/2$ .
  - $\Delta S = R \ln 2$ .
  - $\Delta S = 3R/2$ .
  - $\Delta S = 0$ .

#### 24-3 Entropy Change for Irreversible Processes

- A block of aluminum originally at  $80^\circ\text{C}$  is placed into an insulated container of water originally at  $25^\circ\text{C}$ . After a while the system reaches an equilibrium temperature of  $31^\circ\text{C}$ .
  - During this process
    - $\Delta S_{\text{aluminum}} > 0$ .
    - $\Delta S_{\text{aluminum}} = 0$ .
    - $\Delta S_{\text{aluminum}} < 0$ .
  - During this process
    - $\Delta S_{\text{water}} > 0$ .
    - $\Delta S_{\text{water}} = 0$ .
    - $\Delta S_{\text{water}} < 0$ .
  - During this process
    - $|\Delta S_{\text{water}}| > |\Delta S_{\text{aluminum}}|$ .
    - $|\Delta S_{\text{water}}| = |\Delta S_{\text{aluminum}}|$ .
    - $|\Delta S_{\text{water}}| < |\Delta S_{\text{aluminum}}|$ .

#### 24-4 The Second Law of Thermodynamics

- Which of the following is a consequence of the second law of thermodynamics?
  - Heat can flow only from high temperature to low temperature.
  - Objects in contact will tend toward having the same temperature.
  - Any system that produces order from disorder must have an external influence.

#### 24-5 Entropy and the Performance of Engines

- A Carnot engine discharges 3 J of heat into the low-temperature reservoir for every 2 J of work output.
  - What is the efficiency of this Carnot engine?
    - 1/3
    - 2/5
    - 3/5
    - 2/3

- For this engine  $T_L = 27^\circ\text{C}$ . What can be concluded about  $T_H$ ?
  - $T_H = 627^\circ\text{C}$ .
  - $T_H = 227^\circ\text{C}$ .
  - $T_H > 627^\circ\text{C}$ .
  - $T_H < 227^\circ\text{C}$ .
  - $227^\circ\text{C} < T_H < 627^\circ\text{C}$ .

#### 24-6 Entropy and the Performance of Refrigerators

- Consider an ideal heat pump and a perfect electric heater. The electric heater converts 100% of the electrical energy into heat energy; the heat pump converts 100% of the electrical energy into work, which then powers a Carnot refrigerator. Which is the more “efficient” way to heat a home? (Ignore maintenance or start-up costs.)
  - The electric heater is always more efficient.
  - The heat pump is always more efficient.
  - The heat pump is more efficient if the outside temperature is not too warm.
  - The heat pump is more efficient if the outside temperature is not too cold.

#### 24-7 The Efficiencies of Real Engines

- A real engine has an efficiency of 33%. The engine has a work output of 24 J per cycle.
  - How much heat energy is extracted from the high-temperature reservoir per cycle?
    - 8 J
    - 16 J
    - 48 J
    - 72 J
    - The question can be answered only if the engine is a Carnot engine.
  - How much heat energy is discharged into the low-temperature reservoir per cycle?
    - 8 J
    - 16 J
    - 48 J
    - 72 J
    - The question can be answered only if the engine is a Carnot engine.
  - For this engine  $T_L = 27^\circ\text{C}$ . What can be concluded about  $T_H$ ?
    - $T_H = 450^\circ\text{C}$ .
    - $T_H = 177^\circ\text{C}$ .
    - $T_H > 177^\circ\text{C}$ .
    - $T_H < 177^\circ\text{C}$ .
    - $177^\circ\text{C} < T_H < 450^\circ\text{C}$ .

- A real engine operates at 75% of the efficiency of a Carnot engine operating between the same two temperatures. This real engine has a power output of 100 W and discharges heat into the  $27^\circ\text{C}$  low-temperature reservoir at a rate of 300 J/s. What is the temperature of the high-temperature reservoir?
  - $27^\circ\text{C}$
  - $77^\circ\text{C}$
  - $127^\circ\text{C}$
  - $177^\circ\text{C}$

#### 24-8 The Second Law Revisited

- An inventor claims to have invented four engines, each of which operates between heat reservoirs at 400 and 300 K.

Data on each engine, per cycle of operation, are as follows:

	$Q_{\text{in}}$	$Q_{\text{out}}$	$ W $
Engine 1	200 J	-175 J	40 J
Engine 2	500 J	-200 J	400 J
Engine 3	600 J	-200 J	400 J
Engine 4	100 J	-90 J	10 J

(a) Which of these engines violate the first law of thermodynamics? (There may be more than one correct answer!)

(A) 1 (B) 2 (C) 3 (D) 4

(b) Which of these engines violate the second law of thermodynamics? (There may be more than one correct answer!)

(A) 1 (B) 2 (C) 3 (D) 4

### 24-9 A Statistical View of Entropy

10. Ten identical particles are to be divided up into two containers.

(a) How many microstates belong to the configuration of three particles in one container and seven in the other?

(A) 120 (B) 30240  
(C) 3628800 (D)  $6.3 \times 10^9$

(b) How many different configurations are possible?

(A) 1 (B) 11  
(C) 120 (D) 1024  
(E) 3628800

(c) What is the total number of microstates for the ten-particle system?

(A) 1 (B) 11  
(C) 120 (D) 1024  
(E) 3628800

(d) Which configuration has the largest number of microstates?

(A) 0, 10 (B) 3, 7 (C) 4, 6 (D) 5, 5

11. Six identical molecules are in one box, and two are in another box. The two boxes are brought together and the molecules mix together so that four molecules are in each box. What is the change in entropy when this happens?

(A)  $k/2$  (B)  $k \ln(5/2)$   
(C)  $k \ln(4/3)$  (D)  $k \ln 20$

## QUESTIONS

- Are any of the following phenomena reversible: (a) breaking an empty soda bottle; (b) mixing a cocktail; (c) winding a watch; (d) melting an ice cube in a glass of iced tea; (e) burning a log of firewood; (f) puncturing an automobile tire; (g) heating electrically an insulated block of metal; (h) isothermally expanding a nonideal gas against a piston; (i) finishing the “Unfinished Symphony”; (j) writing this book?
- Give some examples of irreversible processes in nature.
- Are there any natural processes that are reversible?
- Give a qualitative explanation of how frictional forces between moving surfaces produce internal energy. Why does the reverse process (internal energy producing relative motion of those surfaces) not occur?
- Is a human being a heat engine? Explain.
- Could we not just as well define the efficiency of an engine as  $\epsilon = |W|/|Q_{\text{out}}|$  rather than as  $\epsilon = |W|/|Q_{\text{in}}|$ ? Why don't we?
- The efficiencies of nuclear power plants are less than those of fossil-fuel plants. Why?
- Can a given amount of mechanical energy be converted completely into heat energy? If so, give an example.
- An inventor suggested that a house might be heated in the following manner: A system resembling a refrigerator draws heat from the Earth and rejects heat to the house. The inventor claimed that the heat supplied to the house can exceed the work done by the engine of the system. What is your comment?
- Comment on the statement: “A heat engine converts disordered mechanical motion into organized mechanical motion.”
- Is a heat engine operating between the warm surface water of a tropical ocean and the cooler water beneath the surface a possible concept? Is the idea practical? (See “Solar Sea Power,” by Clarence Zener, *Physics Today*, January 1973, p. 48.)
- Can we calculate the work done during an irreversible process in terms of an area on a  $pV$  diagram? Is any work done?
- If a Carnot engine is independent of the working substance, then perhaps real engines should be similarly independent, to

a certain extent. Why then, for real engines, are we so concerned to find suitable fuels such as coal, gasoline, or fissionable material? Why not use stones as fuel?

- Under what conditions would an ideal heat engine be 100% efficient?
- What factors reduce the efficiency of a heat engine from its ideal value?
- You wish to increase the efficiency of a Carnot engine as much as possible. You can do this by increasing  $T_{\text{H}}$  a certain amount, keeping  $T_{\text{L}}$  constant, or by decreasing  $T_{\text{L}}$  the same amount, keeping  $T_{\text{H}}$  constant. Which would you do?
- Explain why a room can be warmed by leaving open the door of an oven but cannot be cooled by leaving open the door of a kitchen refrigerator.
- Why do you get poorer gasoline mileage from your car in winter than in summer?
- From time to time inventors will claim to have perfected a device that does useful work but consumes no (or very little) fuel. What do you think is most likely true in such cases: (a) the claimants are right, (b) the claimants are mistaken in their measurements, or (c) the claimants are swindlers? Do you think that such a claim should be examined closely by a panel of scientists and engineers? In your opinion, would the time and effort be justified?
- We have seen that real engines always discard substantial amounts of heat to their low-temperature reservoirs. It seems a shame to throw this heat energy away. Why not use this heat to run a second engine, the low-temperature reservoir of the first engine serving as the high-temperature reservoir of the second?
- Give examples in which the entropy of a system decreases and explain why the second law of thermodynamics is not violated.
- Do living things violate the second law of thermodynamics? As a chicken grows from an egg, for example, it becomes

more and more ordered and organized. Increasing entropy, however, calls for disorder and decay. Is the entropy of a chicken actually decreasing as it grows?

23. Two containers of gases at different temperatures are isolated from the surroundings and separated from each other by a partition that allows heat exchange. What would have to happen if the entropy were to decrease? To increase? What is likely to happen?
24. Is there a change in entropy in purely mechanical motions?
25. Show that the total entropy increases when work is converted into heat by friction between sliding surfaces. Describe the increase in disorder.
26. Heat energy flows from the Sun to the Earth. Show that the entropy of the Earth–Sun system increases during this process.
27. Is it true that the heat energy of the universe is steadily growing less available? If so, why?
28. Consider a box containing a very small number of molecules—say, five. It must sometimes happen by chance that all these molecules find themselves in the left half of the box, the right half being completely empty. This is simply the reverse of free expansion, a process that we have declared to be *irreversible*. What is your explanation?
29. A rubber band feels warmer than its surroundings immediately after it is quickly stretched; it becomes noticeably cooler when it is allowed to contract suddenly. Also, a rubber band supporting a load contracts on being heated. Explain these observations using the fact that the molecules of rubber consist of intertwined and cross-linked long chains of atoms in roughly random orientation.
30. What entropy change occurs, if any, when a pack of 52 cards is shuffled into one particular arrangement? Is the concept of

entropy appropriate in this case? If so, explain how one could get useful cooling by carrying out this process adiabatically.

31. Discuss the following comment of Panofsky and Phillips: “From the standpoint of formal physics there is only one concept which is asymmetric in the time, namely, entropy. But this makes it reasonable to assume that the second law of thermodynamics can be used to ascertain the sense of time independent of any frame of reference; that is, we shall take the positive direction of time to be that of statistically increasing disorder, or increasing entropy.” (See, in this connection, “The Arrow of Time,” by David Layzer, *Scientific American*, December 1975, p. 56.)
32. Explain the statement: “Cosmic rays continually *decrease* the entropy of the Earth on which they fall.” Why does this not contradict the second law of thermodynamics?
33. When we put cards together in a deck or put bricks together to build a house, for example, we increase the order in the physical world. Does this violate the second law of thermodynamics? Explain.
34. Can one use terrestrial thermodynamics, which is known to apply to bounded and isolated bodies, for the whole universe? If so, is the universe bounded and from what is the universe isolated?
35. Temperature and pressure are examples of *intensive* properties of a system, their values for any sample of the system being independent of the size of the sample. However, entropy, like internal energy, is an *extensive* property, its value for any sample of a system being proportional to the size of the sample. Discuss.
36. The first and second laws of thermodynamics may be paraphrased, respectively, as follows: (1) You cannot win. (2) You cannot even break even. Explain in what sense these are permissible restatements.

## EXERCISES

### 24-1 One-Way Processes

### 24-2 Defining Entropy Change

1. An ideal gas undergoes a reversible isothermal expansion at  $132^\circ\text{C}$ . The entropy of the gas increases by  $46.2\text{ J/K}$ . How much heat is absorbed?
2. In Fig. 24-18, suppose that the change in entropy of the system in passing from state  $a$  to state  $b$  along path 1 is  $+0.60\text{ J/K}$ . What is the entropy change in passing (a) from state  $a$  to  $b$  along path 2 and (b) from state  $b$  to  $a$  along path 2?

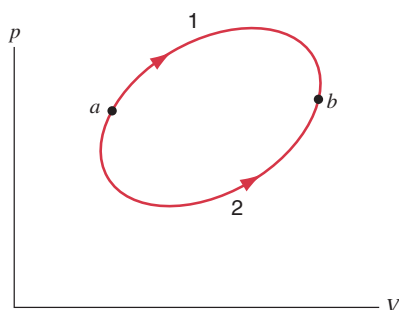

FIGURE 24-18. Exercise 2.

3. For the Carnot cycle shown in Fig. 24-19, calculate (a) the heat that enters and (b) the work done on the system.

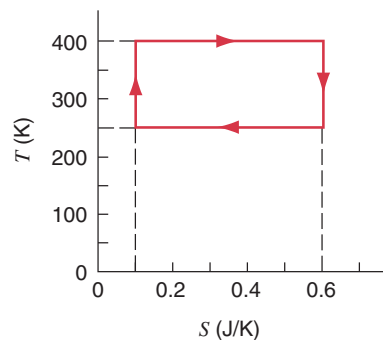

FIGURE 24-19. Exercise 3.

4. Four moles of an ideal gas are caused to expand from a volume  $V_1$  to a volume  $V_2 = 3.45V_1$ . (a) If the expansion is isothermal at the temperature  $T = 410\text{ K}$ , find the work done on the expanding gas. (b) Find the change in entropy, if any. (c) If the expansion is reversibly adiabatic instead of isothermal, what is the entropy change?

- Find (a) the heat absorbed and (b) the change in entropy of a 1.22-kg block of copper whose temperature is increased reversibly from 25.0 to 105°C.
- Heat can be transferred from water at 0°C and atmospheric pressure without causing the water to freeze, if done with little disturbance of the water. Suppose the water is cooled to -5.0°C before ice begins to form. Find the change in entropy occurring during the sudden freezing of 1.0 g of water that then takes place.

### 24-3 Entropy Change for Irreversible Processes

- An ideal gas undergoes an isothermal expansion at 77°C increasing its volume from 1.3 to 3.4 L. The entropy change of the gas is 24 J/K. How many moles of gas are present?
- Suppose that the same amount of heat energy—say, 260 J—is transferred by conduction from a heat reservoir at a temperature of 400 K to another reservoir, the temperature of which is (a) 100 K, (b) 200 K, (c) 300 K, and (d) 360 K. Calculate the changes in entropy and discuss the trend.
- A brass rod is in thermal contact with a heat reservoir at 130°C at one end and a heat reservoir at 24.0°C at the other end. (a) Compute the total change in the entropy arising from the process of conduction of 1200 J of heat through the rod. (b) Does the entropy of the rod change in the process?

### 24-4 The Second Law of Thermodynamics

- A 50.0-g block of copper having a temperature of 400 K is placed in an insulating box with a 100-g block of lead having a temperature of 200 K. (a) What is the equilibrium temperature of this two-block system? (b) What is the change in the internal energy of the two-block system as it changes from the initial condition to the equilibrium condition? (c) What is the change in the entropy of the two-block system? (See Table 23-2.)
- A mixture of 1.78 kg of water and 262 g of ice at 0°C is, in a reversible process, brought to a final equilibrium state where the water/ice ratio, by mass, is 1:1 at 0°C. (a) Calculate the entropy change of the system during this process. (b) The system is then returned to the first equilibrium state, but in an irreversible way (by using a Bunsen burner, for instance). Calculate the entropy change of the system during this process. (c) Show that your answer is consistent with the second law of thermodynamics.
- In a specific heat experiment, 196 g of aluminum at 107°C is mixed with 52.3 g of water at 18.6°C. (a) Calculate the equilibrium temperature. Find the entropy change of (b) the aluminum and (c) the water. (d) Calculate the entropy change of the system. (Hint: See Sample Problem 24-3.)

### 24-5 Entropy and the Performance of Engines

- A heat engine absorbs 52.4 kJ of heat and exhausts 36.2 kJ of heat each cycle. Calculate (a) the efficiency and (b) the work done by the engine per cycle.
- A car engine delivers 8.18 kJ of work per cycle. (a) Before a tune-up, the efficiency is 25.0%. Calculate, per cycle, the heat absorbed from the combustion of fuel and the heat exhausted to the atmosphere. (b) After a tune-up, the efficiency is 31.0%. What are the new values of the quantities calculated in (a)?
- Calculate the efficiency of a fossil-fuel power plant that consumes 382 metric tons of coal each hour to produce useful

work at the rate of 755 MW. The heat of combustion of coal is 28.0 MJ/kg.

- Engine A, compared to engine B, produces, per cycle, five times the work but receives three times the heat input and exhausts out twice the heat. Determine the efficiency of each engine.
- In a Carnot cycle, the isothermal expansion of an ideal gas takes place at 412 K and the isothermal compression at 297 K. During the expansion, 2090 J of heat energy are transferred to the gas. Determine (a) the work performed by the gas during the isothermal expansion, (b) the heat rejected from the gas during the isothermal compression, and (c) the work done on the gas during the isothermal compression.
- A Carnot engine has an efficiency of 22%. It operates between heat reservoirs differing in temperature by 75°C. Find the temperatures of the reservoirs.
- For the Carnot cycle illustrated in Fig. 24-8, show that the work done by the gas during process *BC* has the same absolute value as the work done on the gas during process *DA*.
- (a) In a two-stage Carnot heat engine, a quantity of heat  $|Q_1|$  is absorbed at a temperature  $T_1$ , work  $|W_1|$  is done, and a quantity of heat  $|Q_2|$  is expelled at a lower temperature  $T_2$ , by the first stage. The second stage absorbs the heat expelled by the first, does work  $|W_2|$ , and expels a quantity of heat  $|Q_3|$  at a lower temperature  $T_3$ . Prove that the efficiency of the combination is  $(T_1 - T_3)/T_1$ . (b) A combination mercury-steam turbine takes saturated mercury vapor from a boiler at 469°C and exhausts it to heat a steam boiler at 238°C. The steam turbine receives steam at this temperature and exhausts it to a condenser at 37.8°C. Calculate the maximum efficiency of the combination.
- In a steam locomotive, steam at a boiler pressure of 16.0 atm enters the cylinders, is expanded adiabatically to 5.60 times its original volume, and then is exhausted to the atmosphere. Calculate (a) the steam pressure after expansion and (b) the greatest possible efficiency of the engine.
- One mole of an ideal monatomic gas is used as the working substance of an engine that operates on the cycle shown in Fig. 24-20. Calculate (a) the work done by the engine per cycle, (b) the heat added per cycle during the expansion stroke *abc*, and (c) the engine efficiency. (d) What is the Carnot efficiency of an engine operating between the highest and lowest temperatures present in the cycle? How does this compare to the efficiency calculated in (c)? Assume that  $p_1 = 2p_0$ ,  $V_1 = 2V_0$ ,  $p_0 = 1.01 \times 10^5$  Pa, and  $V_0 = 0.0225$  m<sup>3</sup>.

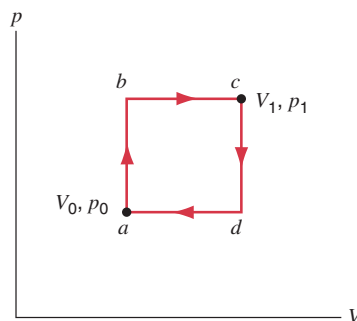

FIGURE 24-20. Exercise 22.

**24-6 Entropy and the Performance of Refrigerators**

23. To make some ice, a freezer extracts 185 kJ of heat at  $-12.0^{\circ}\text{C}$ . The freezer has a coefficient of performance of 5.70. The room temperature is  $26.0^{\circ}\text{C}$ . (a) How much heat is delivered to the room? (b) How much work is required to run the freezer?
24. A refrigerator does 153 J of work to transfer 568 J of heat from its cold compartment. (a) Calculate the refrigerator's coefficient of performance. (b) How much heat is exhausted to the kitchen?
25. How much work must be done to extract 10.0 J of heat (a) from a reservoir at  $7^{\circ}\text{C}$  and transfer it to one at  $27^{\circ}\text{C}$  by means of a refrigerator using a Carnot cycle; (b) from one at  $-73^{\circ}\text{C}$  to one at  $27^{\circ}\text{C}$ ; (c) from one at  $-173^{\circ}\text{C}$  to one at  $27^{\circ}\text{C}$ ; and (d) from one at  $-223^{\circ}\text{C}$  to one at  $27^{\circ}\text{C}$ ?
26. Apparatus that liquefies helium is in a laboratory at 296 K. The helium in the apparatus is at 4.0 K. If 150 mJ of heat is transferred from the helium, find the minimum amount of heat delivered to the laboratory.
27. An air conditioner takes air from a room at  $70^{\circ}\text{F}$  and transfers it to the outdoors, which is at  $95^{\circ}\text{F}$ . For each joule of electrical energy required to run the refrigerator, how many joules of heat are transferred from the room?
28. An inventor claims to have created a heat pump that draws heat from a lake at  $3.0^{\circ}\text{C}$  and delivers heat at a rate of 20 kW to a building at  $35^{\circ}\text{C}$ , while using only 1.9 kW of electrical power. How would you judge the claim?
29. (a) A Carnot engine operates between a hot reservoir at 322 K and a cold reservoir at 258 K. If it absorbs 568 J of heat per cycle at the hot reservoir, how much work per cycle does it deliver? (b) If the same engine, working in reverse, functions as a refrigerator between the same two reservoirs, how much work per cycle must be supplied to transfer 1230 J of heat from the cold reservoir?
30. A heat pump is used to heat a building. The outside temperature is  $-5.0^{\circ}\text{C}$  and the temperature inside the building is to be maintained at  $22^{\circ}\text{C}$ . The coefficient of performance is 3.8, and the pump delivers 7.6 MJ of heat to the building each hour. At what rate must work be done to run the pump?
31. In a refrigerator the low-temperature coils are at a temperature of  $-13^{\circ}\text{C}$  and the compressed gas in the condenser has a temperature of  $25^{\circ}\text{C}$ . Find the coefficient of performance of a Carnot refrigerator operating between these temperatures.
32. The motor in a refrigerator has a power output of 210 W. The freezing compartment is at  $-3.0^{\circ}\text{C}$  and the outside air is at

$26^{\circ}\text{C}$ . Assuming that the efficiency is 85% of the ideal, calculate the amount of heat that can be extracted from the freezing compartment in 15 min.

33. A Carnot engine works between temperatures  $T_1$  and  $T_2$ . It drives a Carnot refrigerator that works between two different temperatures  $T_3$  and  $T_4$  (see Fig. 24-21). Find the ratio  $|Q_3|/|Q_1|$  in terms of the four temperatures.

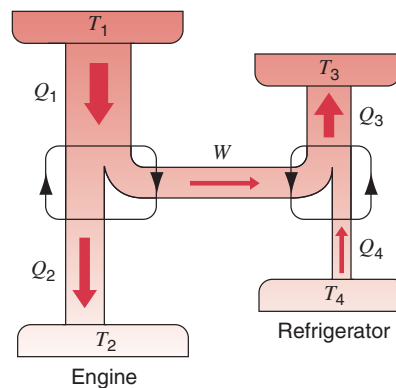

FIGURE 24-21. Exercise 33.

**24-7 The Efficiencies of Real Engines**

**24-8 The Second Law Revisited**

**24-9 A Statistical View of Entropy**

34. (a) Derive Stirling's approximation (Eq. 24-21) by substituting an integral for the sum in the expression

$$\ln N! = \sum_{x=1}^N \ln x \approx \int_1^N \ln x \, dx.$$

(b) For what values of  $N$  is the error in Stirling's approximation less than 1%, 0.1%, and  $1 \times 10^{-6}$ ?

35. Consider a container that is divided into two sections. (a) Initially  $N$  molecules of a gas are in one section, and the other side is empty. Compute the multiplicity of this initial state. (b) After a hole is punched in the partition, the gas fills the entire container uniformly, with  $N/2$  molecules on each side of the partition. Find the multiplicity of the final state. (c) Show that the change in entropy is  $\Delta S = kN \ln 2$ . (d) Compare this result with the result of Sample Problem 24-4 for the entropy change in a free expansion, and explain the similarities of the two results.

**PROBLEMS**

1. At very low temperatures, the molar specific heat of many solids is (approximately) proportional to  $T^3$ ; that is,  $C_V = AT^3$  where  $A$  depends on the particular substance. For aluminum,  $A = 3.15 \times 10^{-5} \text{ J/mol} \cdot \text{K}^4$ . Find the entropy change of 4.8 mol of aluminum when its temperature is raised from 5.0 to 10 K.
2. An object of constant heat capacity  $C$  is heated from an initial temperature  $T_i$  to a final temperature  $T_f$  by being placed in

contact with a reservoir at  $T_f$ . Represent the process on a graph of  $C/T$  versus  $T$  and show graphically that the total change in entropy  $\Delta S$  (object plus reservoir) is positive and (b) show how the use of reservoirs at intermediate temperatures would allow the process to be carried out in a way that makes  $\Delta S$  as small as desired.

3. One mole of an ideal monatomic gas is caused to go through the cycle shown in Fig. 24-22. (a) How much work is done on

the gas in expanding the gas from  $a$  to  $c$  along path  $abc$ ? (b) What is the change in internal energy and entropy in going from  $b$  to  $c$ ? (c) What is the change in internal energy and entropy in going through one complete cycle? Express all answers in terms of the pressure  $p_0$  and volume  $V_0$  at point  $a$  in the diagram.

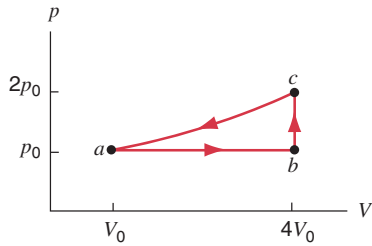

FIGURE 24-22. Problem 3.

4. One mole of an ideal diatomic gas is caused to pass through the cycle shown on the  $pV$  diagram in Fig. 24-23 where  $V_2 = 3V_1$ . Determine, in terms of  $p_1$ ,  $V_1$ ,  $T_1$ , and  $R$ : (a)  $p_2$ ,  $p_3$ , and  $T_3$ ; and (b)  $W$ ,  $Q$ ,  $\Delta E_{\text{int}}$ , and  $\Delta S$  for all three processes.

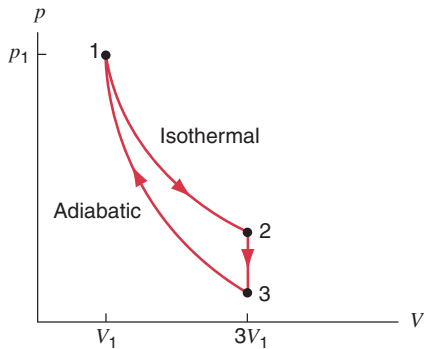

FIGURE 24-23. Problem 4.

5. One mole of a monatomic ideal gas is taken from an initial state of pressure  $p_0$  and volume  $V_0$  to a final state of pressure  $2p_0$  and volume  $2V_0$  by two different processes. (I) It expands isothermally until its volume is doubled, and then its pressure is increased at constant volume to the final state. (II) It is compressed isothermally until its pressure is doubled, and then its volume is increased at constant pressure to the final state. Show the path of each process on a  $pV$  diagram. For each process calculate in terms of  $p_0$  and  $V_0$ : (a) the heat absorbed by the gas in each part of the process; (b) the work done on the gas in each part of the process; (c) the change in internal energy of the gas,  $E_{\text{int},f} - E_{\text{int},i}$ ; and (d) the change in entropy of the gas,  $S_f - S_i$ .
6. A 12.6-g ice cube at  $-10.0^\circ\text{C}$  is placed in a lake whose temperature is  $+15.0^\circ\text{C}$ . Calculate the change in entropy of the system as the ice cube comes to thermal equilibrium with the lake. (Hint: Will the ice cube affect the temperature of the lake?)
7. A system consists of two objects that are allowed to come into thermal contact. Object 1 has mass  $m_1$ , specific heat capacity  $c_1$ , and is originally at temperature  $T_{1,i}$ . Object 2 has mass  $m_2$ , specific heat capacity  $c_2$ , and is originally at temperature  $T_{2,i} < T_{1,i}$ . As object 1 slowly cools, object 2 slowly
- warms. (a) Write an expression for the temperature of object 2,  $T_2$ , as a function of the temperature of object 1,  $T_1$ . (b) Find the change in entropy of the system  $\Delta S$  as a function of  $T_1$ . (c) Show that  $\Delta S$  is a maximum when both objects have the same temperature.
8. Two moles of a monatomic ideal gas are caused to go through the cycle shown in Fig. 24-24. Process  $bc$  is a reversible adiabatic expansion. Also,  $p_b = 10.4$  atm,  $V_b = 1.22$  m<sup>3</sup> and  $V_c = 9.13$  m<sup>3</sup>. Calculate (a) the heat added to the gas, (b) the heat leaving the gas, (c) the net work done by the gas, and (d) the efficiency of the cycle.

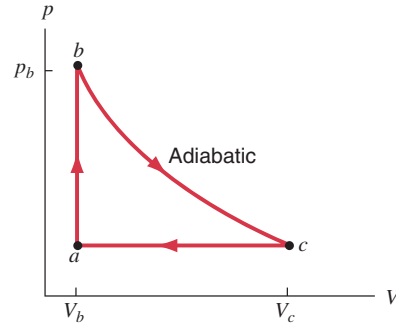

FIGURE 24-24. Problem 8.

9. One mole of a monatomic ideal gas initially at a volume of 10 L and a temperature 300 K is heated at constant volume to a temperature of 600 K, allowed to expand isothermally to its initial pressure, and finally compressed isobarically (that is, at constant pressure) to its original volume, pressure, and temperature. (a) Compute the heat input to the system during one cycle. (b) What is the net work done by the gas during one cycle? (c) What is the efficiency of this cycle?
10. A gasoline internal combustion engine can be approximated by the cycle shown in Fig. 24-25. Assume an ideal diatomic gas and use a compression ratio of 4:1 ( $V_d = 4V_a$ ). Assume that  $p_b = 3p_a$ . (a) Determine the pressure and temperature of each of the vertex points of the  $pV$  diagram in terms of  $p_a$  and  $T_a$ . (b) Calculate the efficiency of the cycle.

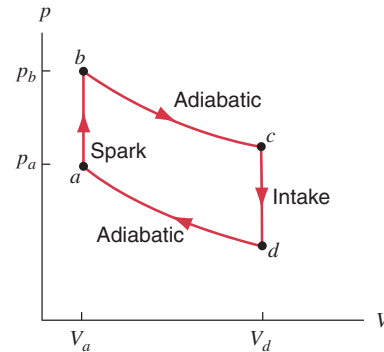

FIGURE 24-25. Problem 10.

11. (a) Plot accurately a Carnot cycle on a  $pV$  diagram for 1.00 mol of an ideal gas. Let point A (see Fig. 24-8) correspond to  $p = 1.00$  atm,  $T = 300$  K, and let point B correspond to 0.500 atm,  $T = 300$  K; take the low-temperature reservoir to be at 100 K. Let  $\gamma = 1.67$ . (b) Compute graphically the work done in this cycle. (c) Compute the work analytically.